

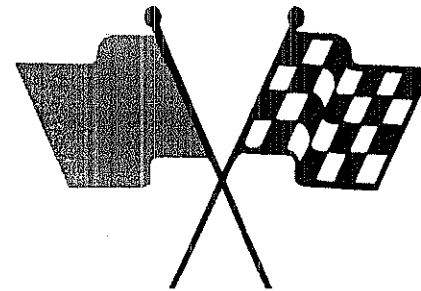

MERCURY
Racing



*Operation, Maintenance
& Warranty Manual*



EPA Emissions Regulations

Outboards manufactured by Mercury Marine in the United States are certified to the United States Environmental Protection Agency as conforming to the requirements of the regulations for the control of air pollution from new outboard motors. This certification is contingent on certain adjustments being set to factory standards. For this reason, the factory procedure for servicing the product must be strictly followed and, wherever practicable, returned to the original intent of the design. **Maintenance, replacement, or repair of the emission control devices and systems may be performed by any marine engine repair establishment or individual.**

Engines are labeled with an Emission Control Information decal as permanent evidence of EPA certification.

WARNING

The engine exhaust from this product contains chemicals known to the state of California to cause cancer, birth defects or other reproductive harm.

Warranty Message

The product you have purchased comes with a **limited warranty** from Mercury Marine, the terms of the warranty are set forth in the *Warranty Information* Section of this manual. The warranty statement contains a description of what is covered, what is not covered, the duration of coverage, how to best obtain warranty coverage, **important disclaimers and limitations of damages**, and other related information. Please review this important information.

Thank You . . .

for your purchase of one of the finest outboards available. You have made a sound investment in boating pleasure. Your outboard has been manufactured by Mercury Racing, a unit of Mercury Marine, the world leader in marine technology and outboard manufacturing since 1939. These years of experience have been committed to the goal of producing the finest quality products. This has led to Mercury Racing's reputation for strict quality control, excellence, durability, lasting performance and being the best at providing after-the-sale support.

Please read this manual carefully before operating your outboard. This manual has been prepared to assist you in the operation, safe use and care of your outboard.

All of us at Mercury Racing took pride in building your outboard and wish you many years of happy and safe boating.

Again, thank you for your confidence in Mercury Marine.

MERCURY
Racing

Mercury Racing
N7480 County Road "UU"
Fond du Lac, WI 54935-9585

TABLE OF CONTENTS

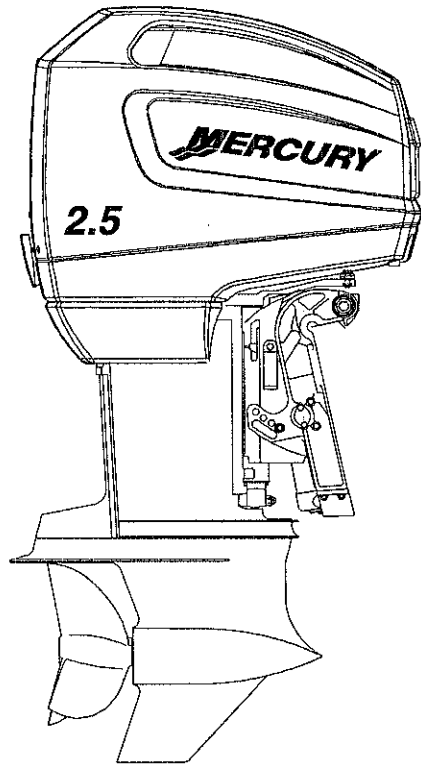

The description and specifications contained herein were in effect at the time this manual was approved for printing. Mercury Marine, whose policy is one of continued improvement, reserves the right to discontinue models at any time, to change specifications, designs, methods, or procedures without notice and without incurring obligation.

Mercury Marine, Fond du Lac, Wisconsin U.S.A. Litho in U.S.A.

© 2000, Mercury Marine

The following are registered trademarks of Brunswick Corporation: AutoBlend, Force, Jet-Prop, Mariner, Merc, MerCathode, MerCruiser, Mercury, Mercury Marine, Mercury Racing, Quicksilver, Ride-Guide and Thruster.

Warranty Information

Transfer Of Warranty	5
Warranty Registration	6
Mercury RACING DIVISION One Year Limited Warranty	8
Mercury RACING DIVISION 3 Year Limited Warranty Against Corrosion Failure	12
Warranty Coverage and Exclusions for Mercury Racing Outboard and Sterndrive Products	15

General Information

Boater's Responsibilities	17
Before Operating Your Outboard	17
Boat Horsepower Capacity	18
High-Speed And High-Performance Boat Operation	18
Lanyard Stop Switch	19
Protecting People In The Water	21
Carbon Monoxide Risk	22
Wave And Wake Jumping	24
Impact With Underwater Hazards	25
Selecting Accessories For Your Outboard	27
Safe Boating Suggestions	27
Recording Serial Number	29
Specifications	30
Component Identification	31
Propeller Selection	32

Transporting

Trailer Boat/Outboard	33
-----------------------------	----

TABLE OF CONTENTS

Fuel & Oil

Gasoline Recommendations	34
Oil Recommendation	35
Gasoline/Oil Mixture	35
Filling Gasoline Tank	36

Features & Controls

Remote Control Features	37
Warning Horn System	38
Power Trim And Tilt	40
Power Trim Operation	41
Tilting Operation	43
Manual Tilting	44

Operation

Engine Break-in - 2.5 EFI, SS, And Offshore	45
Pre-starting Check List	46
Operating In Freezing Temperatures	46
Operating In Salt Water Or Polluted Water	47
Operating At High Elevations	47
Setting Trim Angle While Running Engine at Idle Speed	48
Operating in Shallow Water	48
Starting The Engine	49
Gear Shifting	51
Stopping The Engine	51

TABLE OF CONTENTS

Maintenance

Outboard Care	52
Submerged Outboard	52
Selecting Replacement Parts For Your Outboard	52
EPA Emissions Regulations	53
Inspection And Maintenance Schedule	54
Flushing the Cooling System	56
Top Cowl Removal and Installation	57
Fuel System	58
Steering Link Rod Fasteners	60
Corrosion Control Anodes	61
Propeller Replacement	62
Spark Plug Inspection	64
Battery Inspection	64
Lubrication Points	65
Checking Power Trim Fluid	66
Gear Case Lubricant	67

Storage

Storage Preparation	69
---------------------------	----

Troubleshooting

Troubleshooting	72
-----------------------	----

Engine Wiring Diagram

Engine Wiring Diagram	76
-----------------------------	----

TABLE OF CONTENTS

Owner Service Assistance

Local Repair Service	78
Service Away From Home	78
Parts And Accessories Inquiries	78
Service Assistance	79
Mercury Marine Service Offices	80

Maintenance Log

Maintenance Log	82
-----------------------	----

Ordering Literature

Ordering Literature	84
---------------------------	----

WARRANTY INFORMATION

Transfer Of Warranty

The limited warranty is transferable to a subsequent purchaser, but only for the remainder of the unused portion of the limited warranty. This will not apply to products used for commercial applications.

DIRECT SALE BY OWNER

The second owner can be registered as the new owner and retain the unused portion of the limited warranty by sending the former owner's plastic Owner Warranty Registration Card and a copy of the bill of sale to show proof of ownership. In the United States and Canada, mail to:

Mercury Marine
 W6250 W. Pioneer Road
 P.O. Box 1939
 Fond du Lac, WI 54936-1939
 Attn: Warranty Registration Department

A new Owner Warranty Registration Card will be issued with the new owner's name and address. Registration records will be changed on the factory computer registration file.

There is no charge for this service.

For products purchased outside the United States and Canada, contact the distributor in your country, or the Mercury Marine Service Office closest to you.

WARRANTY INFORMATION

^{ou1}Warranty Registration

UNITED STATES AND CANADA

1. It is important that your selling dealer fills out the Warranty Registration Card completely and mails it to the factory immediately upon sale of the new product.
2. It identifies name and address of the original purchaser, product model and serial number(s), date of sale, type of use and selling dealer's code, name and address. The dealer also certifies that you are the original purchaser and user of the product.
3. Upon receipt of the Warranty Registration Card at the factory, you will be issued a plastic Owner Warranty Registration Card which is your only valid registration identification. It must be presented to the servicing dealer should warranty service be required. Warranty claims will not be accepted without presentation of this card.
4. A temporary Owner Warranty Registration Card will be presented to you when you purchase the product. It is valid only for 30 days from date of sale while your plastic Owner Warranty Registration Card is being processed. Should your product need service during this period, present the temporary registration card to the dealer. He will attach it to your warranty claim form.
5. Because of your selling dealer's continuing personal interest in your satisfaction, the product should be returned to him for warranty service.
6. If your plastic card is not received within 30 days from date of new product sale, please contact your selling dealer.
7. The product warranty is not effective until the product is registered at the factory.

NOTE: Registration lists must be maintained by factory and dealer on marine products sold in the United States, should notification under the Federal Boat Safety Act be required.

WARRANTY INFORMATION

^{ou2}Warranty Registration (cont.)

OUTSIDE THE UNITED STATES AND CANADA

1. It is important that your selling dealer fills out the Warranty Registration Card completely and mails it to the distributor or Marine Power Service Center responsible for administering the warranty registration/claim program for your area.
2. The Warranty Registration Card identifies your name and address, product model and serial number(s), date of sale, type of use and the selling distributor's/dealer's code number, name and address. The distributor/dealer also certifies that you are the original purchaser and user of the product.
3. A copy of the Warranty Registration Card, designated as the "Purchaser's Copy", MUST be given to you immediately after the card has been completely filled out by the selling distributor/dealer. This card represents your factory registration identification, and should be retained by you for future use when required. Should you ever require warranty service on this product, your dealer may ask you for the Warranty Registration Card to verify date of purchase and to use the information on the card to prepare the warranty claim form(s).
4. In some countries, the Marine Power Service Center will issue you a permanent (plastic) Warranty Registration Card within 30 days after receiving the "Factory Copy" of the Warranty Registration Card from your distributor/dealer. If you receive a plastic Warranty Registration Card, you may discard the "Purchaser's Copy" that you received from the distributor/dealer when you purchased the product. Ask your distributor/dealer if this plastic card program applies to you.
5. For further information concerning the Warranty Registration Card and its relationship to Warranty Claim processing, refer to the "International Warranty".

IMPORTANT: Registration lists must be maintained by the factory and dealer in some countries by law. It is our desire to have ALL products registered at the factory should it ever be necessary to contact you. Make sure your dealer/distributor fills out the warranty registration card immediately and sends the factory copy to the Marine Power International Service Center for your area.

WARRANTY INFORMATION

Mercury RACING DIVISION One Year Limited Warranty

WHAT IS COVERED

Mercury Marine warrants its new products to be free of defects in material and workmanship during the period described below.

DURATION OF COVERAGE

This Limited Warranty provides coverage for one (1) year from either the date the product is first sold to a recreational use retail purchaser, or the date on which the product is first put into service, whichever occurs first. The repair or replacement of parts, or the performance of service under this warranty, does not extend the life of this warranty beyond its original expiration date. Unexpired warranty coverage can be transferred to a subsequent purchaser upon proper re-registration of the product.

CONDITIONS THAT MUST BE MET IN ORDER TO OBTAIN WARRANTY COVERAGE

Warranty coverage is available only to retail customers that purchase from a Dealer authorized by Mercury Marine to distribute the product in the country in which the sale occurred, and then only after the Mercury Marine specified pre-delivery inspection process is completed and documented. Warranty coverage becomes available upon proper registration of the product by the authorized dealer. Inaccurate warranty registration information regarding recreational use, or subsequent change of use from recreational to commercial may void the warranty at the sole discretion of Mercury Marine. Routine maintenance outlined in the Operation and Maintenance Manual must be timely performed in order to maintain warranty coverage. Mercury Marine reserves the right to make warranty coverage contingent upon proof of proper maintenance.

WARRANTY INFORMATION

Mercury RACING DIVISION One Year Limited Warranty (cont.)

WHAT MERCURY WILL DO

Mercury's sole and exclusive obligation under this warranty is limited to, at our option, repairing a defective part, replacing such part or parts with new or Mercury Marine certified re-manufactured parts, or refunding the purchase price of the Mercury product. Mercury reserves the right to improve or modify products from time to time without assuming an obligation to modify products previously manufactured.

HOW TO OBTAIN WARRANTY COVERAGE

The customer must provide Mercury with a reasonable opportunity to repair and reasonable access to the product for warranty service. Warranty claims shall be made by delivering the product for inspection to a Mercury dealer authorized to service the product. If purchaser cannot deliver the product to such a dealer, written notice must be given to Mercury. We will then arrange for the inspection and any covered repair. Purchaser in that case shall pay for all related transportation charges and/or travel time. If the service provided is not covered by this warranty, purchaser shall pay for all related labor and material, and any other expenses associated with that service. Purchaser shall not, unless requested by Mercury, ship the product or parts of the product directly to Mercury. The warranty registration card is the only valid registration identification and must be presented to the dealer at the time warranty service is requested in order to obtain coverage.

WARRANTY INFORMATION

Mercury RACING DIVISION One Year Limited Warranty (cont.)

WHAT IS NOT COVERED

This limited warranty does not cover routine maintenance items, tune ups, adjustments, normal wear and tear, damage caused by abuse, abnormal use, use of a propeller or gear ratio that does not allow the engine to run in its recommended wide-open-throttle RPM range (see the Operation and Maintenance Manual), operation of the product in a manner inconsistent with the recommended operation/duty cycle section of the Operation and Maintenance Manual, neglect, accident, submersion, improper installation (proper installation specifications and techniques are set forth in the installation instructions for the product), improper service, use of an accessory or part not manufactured or sold by us, operation with fuels, oils or lubricants which are not suitable for use with the product (see the Operation and Maintenance Manual), alteration or removal of parts, water entering the engine through the fuel intake, air intake or exhaust system, or damage to the product from insufficient cooling water caused by blockage of the cooling system by a foreign body, running the engine out of water, mounting the engine too high on the transom, or running the boat with the engine trimmed out too far. The commercial use of the product, defined as any work or employment related use of the product, or any income generating use of the product, even if such use is only occasional, will void the warranty. Use of the product for racing or other competitive activity, at any point, even by a prior owner of the product, voids the warranty.

Expenses related to haul-out, launch, towing, storage, telephone, rental, inconvenience, slip fees, insurance coverage, loan payments, loss of time, loss of income, or any other type of incidental or consequential damages are not covered by this warranty. Also, expenses associated with the removal and/or replacement of boat partitions or material caused by boat design for access to the product are not covered by this warranty.

No individual or entity, including Mercury Marine authorized dealers, has been given authority by Mercury Marine to make any affirmation, representation or warranty regarding the product, other than those contained in this limited warranty, and if made, shall not be enforceable against Mercury Marine.

WARRANTY INFORMATION

Mercury RACING DIVISION One Year Limited Warranty (cont.)

For additional information regarding events and circumstances covered by this warranty, and those that are not, see the Warranty Coverage section of the Operation and Maintenance Manual, incorporated by reference into this warranty.

DISCLAIMERS AND LIMITATIONS

THE IMPLIED WARRANTIES OF MERCHANTABILITY AND FITNESS FOR A PARTICULAR PURPOSE ARE EXPRESSLY DISCLAIMED. TO THE EXTENT THAT THEY CANNOT BE DISCLAIMED, THE IMPLIED WARRANTIES ARE LIMITED IN DURATION TO THE LIFE OF THE EXPRESS WARRANTY. INCIDENTAL AND CONSEQUENTIAL DAMAGES ARE EXCLUDED FROM COVERAGE UNDER THIS WARRANTY. SOME STATES/COUNTRIES DO NOT ALLOW FOR THE DISCLAIMERS, LIMITATIONS AND EXCLUSIONS IDENTIFIED ABOVE, AS A RESULT, THEY MAY NOT APPLY TO YOU. THIS WARRANTY GIVES YOU SPECIFIC LEGAL RIGHTS, AND YOU MAY ALSO HAVE OTHER LEGAL RIGHTS WHICH VARY FROM STATE TO STATE AND COUNTRY TO COUNTRY.

WARRANTY INFORMATION

Mercury RACING DIVISION 3 Year Limited Warranty Against Corrosion Failure

(Applicable Only to the United States, Canada and Australia)

WHAT IS COVERED

We warrant each new Mercury, Mariner, Mercury Racing, Sport Jet, M² Jet Drive, Tracker by Mercury Marine Outboard, MerCruiser Inboard or sterndrive engine (Product) rendered inoperative as a direct result of corrosion for the period of time described below.

DURATION OF COVERAGE

This limited corrosion warranty provides coverage for three (3) years from either the date the product is first sold, or the date on which the product is first put into service, whichever occurs first. The repair or replacement of parts, or the performance of service under this warranty does not extend the life of this warranty beyond its original expiration date. Unexpired warranty coverage can be transferred to subsequent (noncommercial use) purchaser upon proper re-registration of the product.

CONDITIONS THAT MUST BE MET IN ORDER TO OBTAIN WARRANTY COVERAGE

Warranty coverage is available only to retail customers that purchase from a Dealer authorized by Mercury Marine to distribute the product in the country in which the sale occurred, and then only after the Mercury Marine specified pre-delivery inspection process is completed and documented. Warranty coverage becomes available upon proper registration of the product by the authorized dealer. Corrosion prevention devices specified in the Operation and Maintenance Manual must be in use on the boat, and routine maintenance outlined in the Operation and Maintenance Manual must be timely performed (including without limitation the replacement of sacrificial anodes, use of specified lubricants, and touch-up of nicks and scratches) in order to maintain warranty coverage. Mercury Marine reserves the right to make warranty coverage contingent upon proof of proper maintenance.

WARRANTY INFORMATION

Mercury RACING DIVISION 3 Year Limited Warranty Against Corrosion Failure (cont.)

WHAT MERCURY WILL DO

Mercury's sole and exclusive obligation under this warranty is limited to, at our option, repairing a corroded part, replacing such part or parts with new or Mercury Marine certified re-manufactured parts, or refunding the purchase price of the Mercury product. Mercury reserves the right to improve or modify products from time to time without assuming an obligation to modify products previously manufactured.

HOW TO OBTAIN WARRANTY COVERAGE

The customer must provide Mercury with a reasonable opportunity to repair, and reasonable access to the product for warranty service. Warranty claims shall be made by delivering the product for inspection to a Mercury dealer authorized to service the product. If purchaser cannot deliver the product to such a dealer, written notice must be given to Mercury. We will then arrange for the inspection and any covered repair. Purchaser in that case shall pay for all related transportation charges and/or travel time. If the service provided is not covered by this warranty, purchaser shall pay for all related labor and material, and any other expenses associated with that service. Purchaser shall not, unless requested by Mercury, ship the product or parts of the product directly to Mercury. The warranty registration card is the only valid registration identification and must be presented to the dealer at the time warranty service is requested in order to obtain coverage.

WHAT IS NOT COVERED

This limited warranty does not cover electrical system corrosion; corrosion resulting from damage, corrosion which causes purely cosmetic damage, abuse or improper service; corrosion to accessories, instruments, steering systems; corrosion to factory installed jet drive unit; damage due to marine growth; product sold with less than a one year limited Product warranty; replacement parts (parts purchased by customer); products used in a commercial application. Commercial use is defined as any work or employment related use of the product, or any use of the product which generates income, for any part of the warranty period, even if the product is only occasionally used for such purposes.

WARRANTY INFORMATION

Mercury RACING DIVISION 3 Year Limited Warranty Against Corrosion Failure (cont.)

Corrosion damage caused by stray electrical currents (on-shore power connections, nearby boats, submerged metal) is not covered by this corrosion warranty and should be protected against by the use of a corrosion protection system, such as the Mercury Precision Parts or Quicksilver MerCathode system and/or Galvanic Isolator. Corrosion damage caused by improper application of copper base anti-fouling paints is also not covered by this limited warranty. If anti-fouling protection is required, Tri-Butyl-Tin-Adipate (TBTA) base anti-fouling paints are recommended on Outboard and MerCruiser boating applications. In areas where TBTA base paints are prohibited by law, copper base paints can be used on the hull and transom. Do not apply paint to the outboard or MerCruiser product. In addition, care must be taken to avoid an electrical interconnection between the warranted product and the paint. Refer to the Operation and Maintenance Manual for additional details.

For additional information regarding events and circumstances covered by this warranty, and those that are not, see the Warranty Coverage section of the Operation and Maintenance Manual, incorporated by reference into this warranty.

DISCLAIMERS AND LIMITATIONS

THE IMPLIED WARRANTIES OF MERCHANTABILITY AND FITNESS FOR A PARTICULAR PURPOSE ARE EXPRESSLY DISCLAIMED. TO THE EXTENT THAT THEY CANNOT BE DISCLAIMED, THE IMPLIED WARRANTIES ARE LIMITED IN DURATION TO THE LIFE OF THE EXPRESS WARRANTY. INCIDENTAL AND CONSEQUENTIAL DAMAGES ARE EXCLUDED FROM COVERAGE UNDER THIS WARRANTY. SOME STATES/COUNTRIES DO NOT ALLOW FOR THE DISCLAIMERS, LIMITATIONS AND EXCLUSIONS IDENTIFIED ABOVE, AS A RESULT, THEY MAY NOT APPLY TO YOU. THIS WARRANTY GIVES YOU SPECIFIC LEGAL RIGHTS, AND YOU MAY ALSO HAVE OTHER LEGAL RIGHTS WHICH VARY FROM STATE TO STATE AND COUNTRY TO COUNTRY.

WARRANTY INFORMATION

Warranty Coverage and Exclusions for Mercury Racing Outboard and Sterndrive Products

The purpose of this section is to help eliminate some of the more common misunderstandings regarding warranty coverage. The following information explains some of the types of services that are not covered by warranty. The provisions set forth following have been incorporated by reference into the Mercury Racing Division Three Year Limited Warranty Against Corrosion Failure, the Mercury Racing Division 90 Day and One Year Limited Warranties.

Keep in mind that warranty covers repairs that are needed within the warranty period because of defects in material and workmanship. Installation errors, accidents, normal wear, and a variety of other causes that affect the product are not covered.

Warranty is limited to defects in material or workmanship, but only to retail customers that purchase from a Dealer authorized by Mercury Marine to distribute the product in the country in which the sale occurred, and then only after the Mercury Marine specified pre-delivery inspection process is completed and documented.

Should you have any questions concerning warranty coverage, contact your authorized dealer. They will be pleased to answer any questions that you may have.

GENERAL EXCLUSIONS FROM WARRANTY

- 1 Corrosion damage incurred by your 900 SC MerCruiser product(s) is not covered under this warranty.
- 2 Minor adjustments and tune-ups, including checking, cleaning or adjusting spark plugs, ignition components, carburetor or EFI settings, filters, belts, controls, and checking lubrication made in connection with normal services.
- 3 Damage caused by lack of maintenance.
- 4 Haul-out, launch, towing charges, and all related transportation charges and/or travel time, etc.
- 5 Additional service work requested by customer other than that necessary to satisfy the warranty obligation.

WARRANTY INFORMATION

Warranty Coverage and Exclusions for Mercury Racing Outboard and Sterndrive Products (cont.)

- 6 Labor performed by other than an authorized dealer may be covered only under following circumstances: When performed on emergency basis (providing there are no authorized dealers in the area who can perform the work required or have no facilities to haul out, etc., and prior factory approval has been given to have the work performed at this facility).
- 7 Use of other than Mercury Precision or Quicksilver parts when making warranty repairs.
- 8 Engine noise does not necessarily indicate a serious engine problem. If diagnosis indicates a serious internal engine condition which could result in a failure, condition responsible for noise should be corrected under the warranty.
- 9 Lower unit and/or propeller damage caused by striking a submerged object is considered a marine hazard.
- 10 Water in the starter motor.
- 11 Starter motors and/or armatures or field coil assembly, which are burned, or where lead is thrown out of commutator because of excess cranking.
- 12 Valve or valve seat grinding required because of wear.

ob

GENERAL INFORMATION

oba1

Boater's Responsibilities

The boat driver is responsible for correct and safe operation of the boat and safety of its occupants and general public. It is strongly recommended that each operator (driver) read and understand this entire manual before operating the outboard.

Be sure at least one additional person on board is instructed in the basics of starting and operating the outboard and boat handling in case the driver is unable to operate the boat.

obb1

Before Operating Your Outboard

Read this manual carefully. Safety and operating information that is practiced along with using good common sense can help prevent personal injury and product damage. If you have any questions, contact your dealer.

This manual as well as safety labels posted on the outboard use safety alerts to draw your attention to special safety instructions that must be followed.

WARNING

WARNING – Hazards or unsafe practices which COULD result in severe personal injury or death.

CAUTION

CAUTION – Hazards or unsafe practices which could result in minor injury or product or property damage.

GENERAL INFORMATION

gob12

U.S. COAST GUARD CAPACITY	
MAXIMUM HORSEPOWER XXX	
MAXIMUM PERSON CAPACITY (POUNDS)	XXX
MAXIMUM WEIGHT CAPACITY	XXX

1

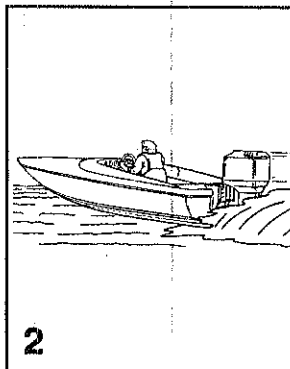

obc1

Boat Horsepower Capacity

- 1 Do not overpower or overload your boat. Most boats will carry a required capacity plate indicating the maximum acceptable power and load as determined by the manufacturer following certain federal guidelines. If in doubt, contact your dealer or the boat manufacturer.

⚠ WARNING

Overpowering a Boat Can Cause:

- **Serious injury, death, or boat damage.**
- **Loss of Boat Control.**
- **Flotation Characteristics of Boat to be Altered from Placing Too Much Weight on Transom.**
- **Boat to Break Apart, Particularly Around the Transom Area.**

abd2

High-Speed And High-Performance Boat Operation

- 2 If you are not familiar with high-performance boat operation we recommend that you first request an orientation/demonstration ride with your dealer or an operator experienced with your boat/outboard combination. Refer to the "Guide to Hi-Performance Boat Operation" booklet (Part Number 90-849250R1) included in your literature packet.

GENERAL INFORMATION

gob8

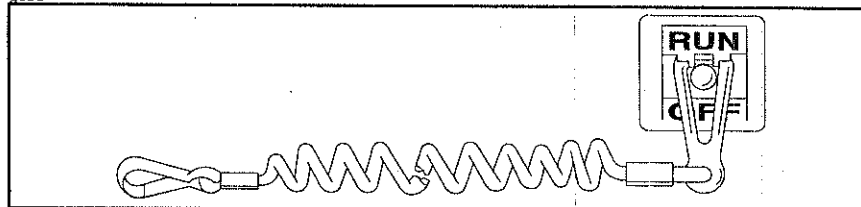

obg6

Lanyard Stop Switch

⚠ WARNING

Should the operator fall out of the boat, the possibility of serious injury or death from being run over by the boat can be greatly reduced by stopping the engine immediately. Always properly connect both ends of the stop switch lanyard – to the stop switch and the operator.

1. The purpose of a lanyard stop switch is to turn off the engine when the operator moves far enough away from the operator's position (as in accidental ejection from the operator's position) to activate the switch. A lanyard stop switch can be installed as an accessory – generally on the dashboard or side adjacent to the operator's position.
2. While activation of the lanyard stop switch will stop the engine immediately, a boat will continue to coast for some distance depending upon the velocity and degree of any turn at shut-down. However, the boat will not complete a full circle. While the boat is coasting, it can cause injury to anyone in the boat's path as seriously as the boat would when under power.

GENERAL INFORMATION

Lanyard Stop Switch (Continued)

⚠ WARNING

Avoid serious injury or death from deceleration forces resulting from in accidental stop switch activation. The boat operator should never leave the operator's station without first disconnecting the stop switch lanyard cord from themselves.

Accidental or unintended activation of the Lanyard Stop Switch during normal operation is a possibility and could cause any, or all, of the following potentially hazardous situations:

1. Occupants could be thrown forward due to unexpected loss of forward motion. – a particular concern for passengers in the front of the boat who could be ejected over the bow and possibly struck by the gear case or propeller.
2. Loss of power and directional control in heavy seas, strong current or high winds.
3. Loss of control when docking.

GENERAL INFORMATION

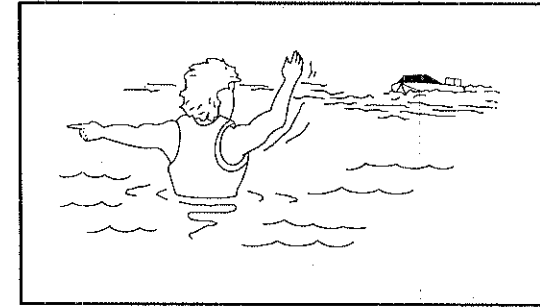

Protecting People In The Water

WHILE YOU ARE CRUISING

It is very difficult for a person in the water to take quick action to avoid a boat heading in their direction even at slow speed.

Always slow down and exercise extreme caution any time you are boating in an area where there might be people in the water.

Whenever a boat is moving (even coasting) even with the outboard in neutral position, there is sufficient force by the water to rotate the propeller. This neutral propeller rotation can cause serious injury.

WHILE BOAT IS STATIONARY

Shift outboard into neutral and shut off the engine before allowing people to swim or be in the water near your boat.

⚠ WARNING

Stop your engine immediately whenever anyone in the water is near your boat. Serious injury to the person in the water is likely if contacted by a rotating propeller, a moving boat, a moving gear case, or any solid device rigidly attached to a moving boat or gear case.

GENERAL INFORMATION

gob4

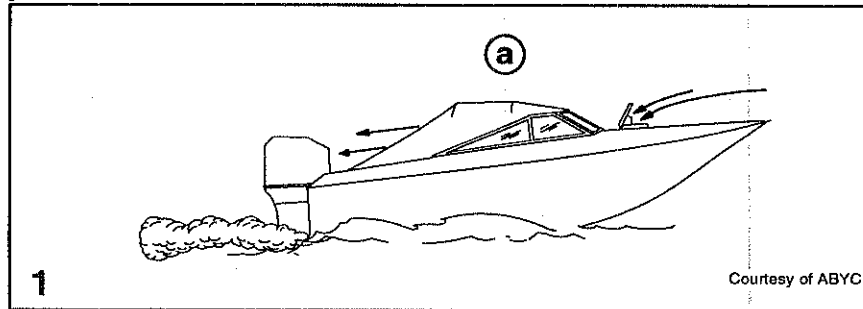

Carbon Monoxide Risk

⚠ WARNING

Avoid the combination of a running engine and poor ventilation. Prolonged exposure to carbon monoxide in sufficient concentration can lead to unconsciousness, brain damage, or death.

Carbon monoxide is a deadly gas that is odorless, colorless and tasteless and is present in the exhaust fumes of all internal combustion engines.

Early symptoms of carbon monoxide poisoning which should not be confused with seasickness or intoxication, include headache, dizziness, drowsiness, and nausea.

SUFFICIENT FRESH AIR FLOW

1 Example of desired air flow through the boat;

- a. Ventilate passenger area, open side curtains, or forward hatches to remove carbon monoxide fumes.

ob

GENERAL INFORMATION

gob39

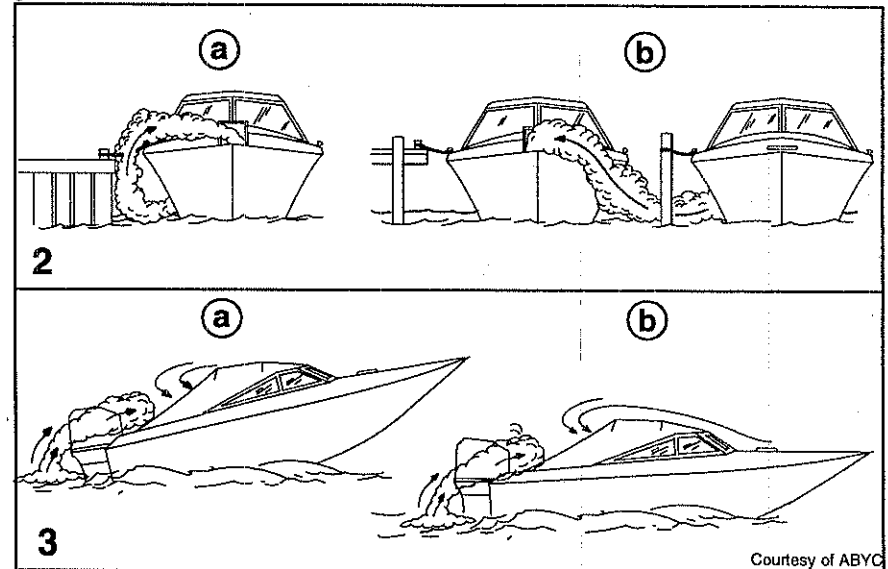

obi3

Carbon Monoxide Risk (Continued)

INSUFFICIENT FRESH AIR FLOW

Under certain conditions, enclosed or canvas enclosed cabins or cockpits with insufficient ventilation may draw in carbon monoxide. Install one or more carbon monoxide detectors in your boat.

Although rare, on a very calm day, swimmers and passengers in an open stationary boat with a running engine, or near a running engine may be exposed to a hazardous level of carbon monoxide.

Insufficient Air Flow Could Occur If:

2 While boat is stationary:

- a. Boat moored in a confined space with the engine running.
- b. Boat is moored close to another boat with its engine running.

3 While boat is moving:

- a. Running the boat with the trim angle of the bow too high.
- b. Running the boat with no forward hatches open (station wagon effect).

GENERAL INFORMATION

gob4

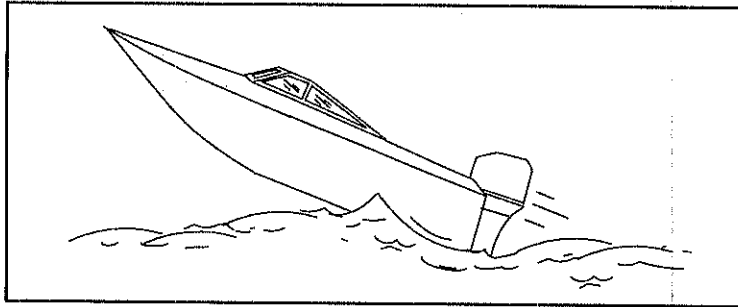

obu1

Wave And Wake Jumping

Operating recreational boats over waves and wakes is a natural part of boating. However, when this activity is done with speed to force the boat hull partially or completely out of the water, certain hazards arise, particularly when the boat re-enters the water.

The primary concern is the boat changing direction while in the midst of the jump. In such case the landing may cause the boat to violently veer in a new direction. Such a sharp change in direction or turn can cause occupants to be thrown out of their seats or out of the boat.

There is another less common hazardous result from allowing your boat to launch off a wave or wake. If the bow of your boat pitches down far enough while airborne, upon water contact it may penetrate under the water surface and "submarine" for an instant. This will bring the boat nearly to a stop in an instant and can send the occupants flying forward. The boat may also steer sharply to one side.

⚠ WARNING

Avoid serious injury or death from being thrown within or out of a boat when it lands after jumping a wave or wake. Avoid wave or wake jumping whenever possible. Instruct all occupants that if a wake or wave jump occurs, get low and hang on to any boat hand hold.

GENERAL INFORMATION

gob4

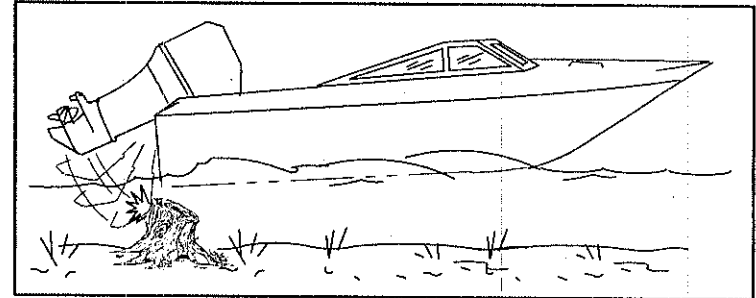

obt1

Impact With Underwater Hazards

Reduce speed and proceed with caution whenever you're driving a boat in shallow water areas or in areas where the waters are suspected of having underwater obstacles that could be struck by the outboard or the boat bottom. **The most important thing you can do to help reduce injury or impact damage from striking a floating or underwater object is control the boat speed. Under these conditions, boat speed should be kept to a minimum planing speed (15 to 25 MPH).**

⚠ WARNING

To avoid serious injury or death from all or part of an outboard coming into the boat after striking a floating or underwater obstacle maintain a top speed no greater than minimum planing speed.

Striking a floating or underwater object could result in an infinite number of situations. Some of these situations could result in the following:

- Part of the outboard or the entire outboard could break loose and fly into the boat.
- The boat could move suddenly in a new direction. Such a sharp change in direction or turn can cause occupants to be thrown out of their seats or out of the boat.
- A rapid reduction in speed. This will cause occupants to be thrown forward, even out of the boat.
- Impact damage to the outboard and/or boat.

(continued on next page)

GENERAL INFORMATION

obn2

Impact With Underwater Hazards (Continued)

Keep in mind, one of the most important things you can do to help reduce injury or impact damage in these situations is control the boat speed. Boat speed should be kept to a minimum planing speed when driving in waters known to have underwater obstacles.

After striking a submerged object, stop the engine as soon as possible and inspect the outboard for any broken or loose parts. If damage is present or suspected, the outboard should be taken to an authorized dealer for a thorough inspection and necessary repair.

The boat should also be checked for any hull fractures, transom fractures, water leaks.

Operating a damaged outboard could cause additional damage to other parts of the outboard, or could affect control of the boat. If continued running is necessary, do so at greatly reduced speeds.

⚠ WARNING

Avoid serious injury or death from loss of boat control. Continued boating with major impact damage can result in sudden outboard component failure with or without subsequent impacts. Have the outboard thoroughly inspected and any necessary repairs made.

GENERAL INFORMATION

obj1

Selecting Accessories For Your Outboard

Genuine Mercury Marine Accessories have been specifically designed and tested for your outboard.

Mercury Marine accessories are available from Mercury Marine dealers.

Some accessories not manufactured or sold by Mercury Marine are not designed to be safely used with your outboard or outboard operating system. Acquire and read the installation, operation, and maintenance manuals for all your selected accessories.

⚠ WARNING

Check with your dealer before installing accessories. Misuse of acceptable accessories or the use of unacceptable accessories can result in serious injury, death, or product failure.

Safe Boating Suggestions

In order to safely enjoy the waterways, familiarize yourself with local and other governmental boating regulations and restrictions, and consider the following suggestions.

Use Life Jackets. Have an approved life jacket of suitable size for each person aboard and have it readily accessible (it is the law). However we strongly recommend that everyone aboard wear their life jacket.

Do not overload your boat. Most boats are rated and certified for maximum load (weight) capacities (refer to your boat capacity plate). If in doubt, contact your dealer or the boats manufacturer.

Perform safety checks and required maintenance. Follow a regular schedule and ensure that all repairs are properly made.

Know and obey all nautical rules and laws of the waterways. Boat operators should complete a boating safety course. Courses are offered in the U.S.A. by (1) The U.S. Coast Guard Auxiliary, (2) The Power Squadron, (3) The Red Cross and (4) your state boating law enforcement agency. Inquiries may be made to the Boating Hotline, 1-800-368-5647 or the Boat U.S. Foundation information number 1-800-336-BOAT.

(continued on next page)

GENERAL INFORMATION

Safe Boating Suggestions (Continued)

Make sure everyone in the boat is properly seated. Don't allow anyone to sit or ride on any part of the boat that was not intended for such use. This includes backs of seats, gunwales, transom, bow, decks, raised fishing seats, any rotating fishing seat; anywhere that sudden unexpected acceleration, sudden stopping, unexpected loss of boat control or sudden boat movement could cause a person to be thrown overboard or into the boat.

Never be under the influence of alcohol or drugs while boating (it is the law). They impair your judgment and greatly reduce your ability to react quickly.

Prepare other boat operators. Instruct at least one person on board in the basics of starting and operating the outboard and boat handling in case the driver becomes disabled or falls overboard.

Passenger boarding. Stop the engine whenever passengers are boarding, unloading or are near the back (stern) of the boat. Just shifting the outboard into neutral is not sufficient.

Be alert. The operator of the boat is responsible by law to "maintain a proper lookout by sight (and hearing)." The operator must have an unobstructed view particularly to the front. No passengers, load, or fishing seats should block the operators view when operating the boat above idle speed.

Never drive your boat directly behind a water skier in case the skier falls. As an example, your boat traveling at 25 miles per hour (40 km/hr) in 5 seconds will overtake a fallen skier who was 200 feet (61m) in front of you.

Boat operators are required by law to file a Boating Accident Report with their state boating law enforcement agency when their boat is involved in certain boating accidents. A boating accident must be reported if: 1. there is loss of life or probable loss of life, 2. there is personal injury requiring medical treatment beyond first aid, 3. there is damage to boats or other property where the damage value exceeds \$500.00 or 4. there is complete loss of the boat. Seek further assistance from local law enforcement.

(continued on next page)

GENERAL INFORMATION

obl2

Recording Serial Number

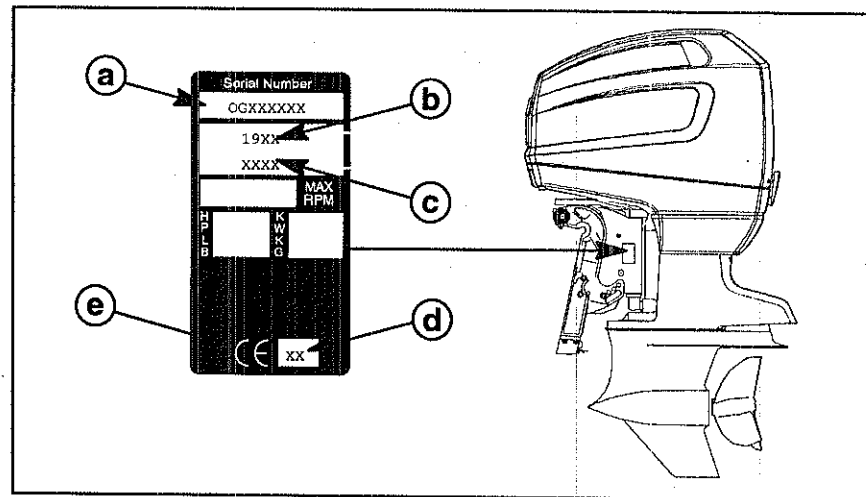

Record the following numbers from your engine as shown for future reference.

- a - Serial Number
- b - Model Year
- c - Model Designation
- d - Year Manufactured
- e - Certified Europe Insignia

GENERAL INFORMATION

Specifications

MODEL	2.5 EFI/EFI SS	EFI OS
Propshaft Horsepower	280	
Propshaft Kilowatts	224	
ECU Box Rev Limit	7750	
Idle RPM	900 In or Out of Gear	
Weight	375 lbs. (170 kg)	400 lbs. (182 kg)
Piston Displacement	153 cu. in. (2.5L - 2507cc)	
Bore	3.50 in. (89mm)	
Stroke	2.65 in (67mm)	
Recommended Spark Plug	Champion QL77CC	
Firing Order	1-2-3-4-5-6	
Idle Speed Pickup Timing	Non Adjustable	
Fuel Pressure	38-40 psi. (262-276 kPa)	
Min. Water Pres. @ 7500 RPM	12 psi. Minimum	
Gear Ratio	1.87:1	
Recommended Gasoline	Refer to Fuel Section	
Recommended Oil	Refer to Fuel Section	
Recommended Gear Case Oil	Mercury Precision Hi-Performance Gear Lube (92-802854A1)	
Gear Case Lubricant Cap.	22.5 fl. oz. (666 ml)	
Battery Rating	Minimum reserve capacity rating of 100 minutes and CCA of 350	
Charging System Output	60 amps Max. (847Watts)	

GENERAL INFORMATION

Component Identification

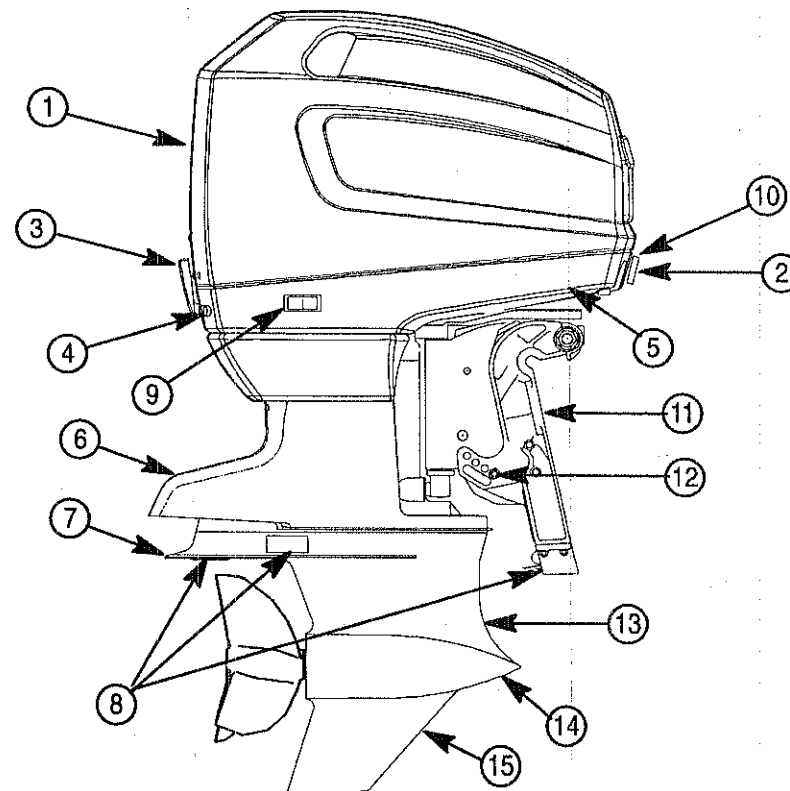

- | | |
|--|---|
| 1. Top Cowl | 9. Cowl Mount Trim Switch |
| 2. Cowl Latch (Front) | 10. Wiring Harness, Fuel line and Control Cables (Install thru bottom cowl) |
| 3. Cowl Latch (Rear) | 11. Transom Brackets |
| 4. Water Pump Indicator Hose (Tell-Tail) | 12. Trim Adjustment Bolt |
| 5. Bottom Cowl | 13. Gear Case |
| 6. Drive Shaft Housing | 14. Cooling Water Intake Holes |
| 7. Anti-Ventilation Plate | 15. Skeg |
| 8. Corrosion Anode(s) | |

GENERAL INFORMATION

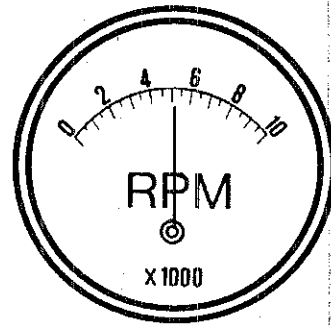

Propeller Selection

Select a propeller that allows the engine to operate in the upper half of the recommended full throttle RPM range with the boat normally loaded (refer to Specifications).

If changing conditions (such as warmer, more humid weather, operation at higher elevations, increased boat load, or a dirty boat bottom/gear case) cause the RPM to drop below the recommended range a propeller change or boat cleaning may be required.

Check full-throttle RPM using an accurate tachometer with the engine trimmed out to a balanced-steering condition (steering effort equal in both directions) without causing the propeller to "break loose."

TRANSPORTING

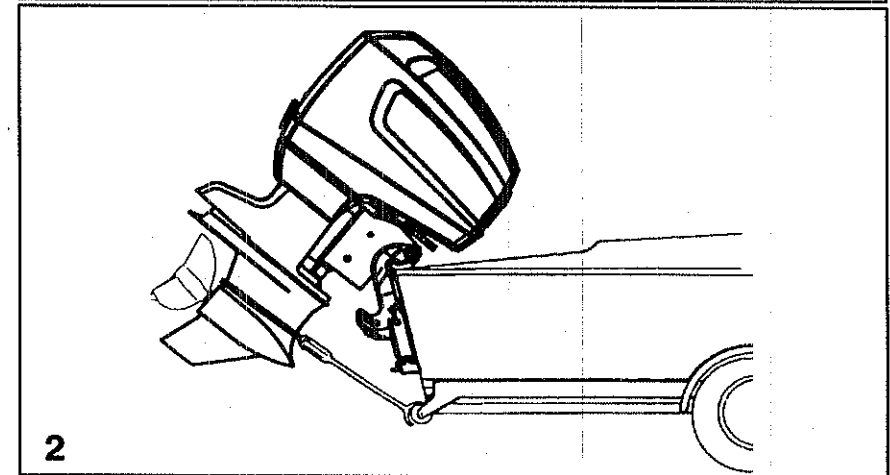
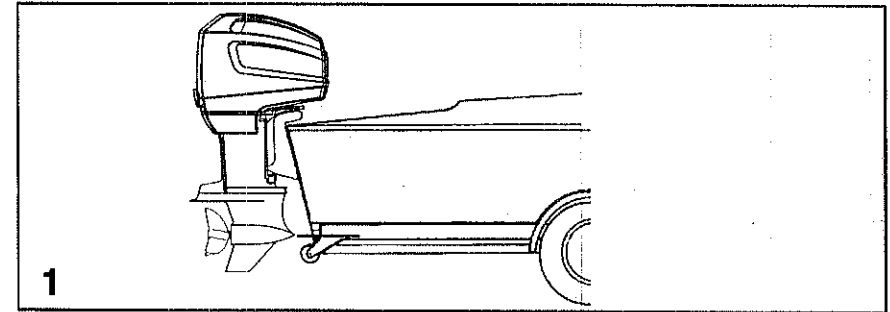

Trailing Boat/Outboard

- 1 Trailer your boat with the outboard tilted down when ever possible (vertical operating position).
- 2 If additional ground clearance is required for, railroad crossings, driveways or trailer bouncing, support the outboard using a support device. Contact your local dealer for recommendations.

IMPORTANT: Do not rely on the power trim/tilt system or tilt support lever to maintain proper ground clearance for trailing. The outboard tilt support lever is not intended to support the outboard for trailing.

To prevent the propeller from spinning freely shift into forward gear.

FUEL & OIL

Gasoline Recommendations

USA AND CANADA

Use a major brand of automotive unleaded gasoline with a minimum posted octane rating (R + M + 2) of 92. Automotive gasolines that contain fuel injector cleaner are recommended for added internal engine cleanliness.

INTERNATIONAL

Use a major brand of automotive unleaded gasoline with a minimum posted octane rating of 98RON. Automotive gasolines that contain fuel injector cleaner are preferred for added internal engine cleanliness. Leaded gasoline is acceptable in areas where unleaded gasoline is not available. However, exhaust passageway corrosion may occur due to the accumulation of exhausted lead particles.

During periods of extended non use, a fuel stabilizer is highly recommended (See Storage Section).

Leaded Gasoline is acceptable to use in areas where unleaded is not available. However, exhaust passageway corrosion may occur due to the accumulation of exhausted lead particles.

ALCOHOL IN GASOLINE

We do not recommend gasoline containing alcohol due to the possible adverse effect the alcohol may have on the fuel system. If only gasoline containing alcohol is available, it must not contain more than 10% ethanol or 5% methanol, and the addition of a Mercury Marine Water Separating Fuel Filter is recommended.

If gasoline containing alcohol is used or if you suspect the presence of alcohol in your gasoline, increase your inspection of the fuel system, visually checking for fuel leaks or abnormalities.

Gasoline containing alcohol may cause the following problems to your outboard and fuel system:

- Corrosion of metal parts.
- Deterioration of elastomers and plastic parts.
- Fuel penetrating through flexible fuel lines.
- Wear and damage of internal engine parts.

(continued on next page)

FUEL & OIL

ALCOHOL IN GASOLINE (CONTINUED)

- Starting and operating difficulties.
- Vapor lock or fuel starvation.

The tendency of gasoline containing alcohol to absorb moisture from the air, results in a phase of water and alcohol which separates from the gasoline in the fuel tank.

The adverse effects of alcohol are more severe with methanol and are worse with increasing content of alcohol.

Oil Recommendation

Use Mercury Precision 2-Cycle Performance Blend Oil (92-813743A2).

Emergency Use Only: If Mercury Precision 2-Cycle Performance Blend Oil is not available, Mercury Precision Premium Plus 2-Cycle TC-W3 Outboard Oil may be substituted. This oil should not be used on a regular basis.

Periodically consult with your dealer to get the latest gasoline and oil recommendations. If Mercury Precision 2-Cycle TC-W3 Outboard Oil is not available, substitute a 2-Cycle outboard manufacturer's oil that is NMMA Certified TC-W3, or another brand of 2-Cycle outboard oil that is NMMA Certified TC-W3. The use of an inferior 2-Cycle outboard oil can reduce engine durability. **Damage from use of inferior oil may not be covered under the limited warranty.**

Gasoline/Oil Mixture

Use a 40:1 (2.5%) gasoline/oil mixture in your fuel tank.

GASOLINE/OIL MIXING RATIO CHART

Gas/Oil Ratio	1 Gallon Gas (3.8 Liters)	3 Gallons Gas (11.5 Liters)	6 Gallons Gas (23 Liters)
40:1 (2.5%)	3.2 fl. oz. (95 ml) Oil	9.6 fl. oz. (283 ml) Oil	19.2 fl. oz. (566 ml) Oil

FUEL & OIL

Filling Gasoline Tank

⚠ WARNING

Avoid serious injury or death from a gasoline fire or explosion. Always stop the engine and **DO NOT** smoke or allow open flames or sparks in the area while filling fuel tanks. To help prevent a static charge during filling, portable fuel tanks must be removed from the boat and placed directly on the ground for filling.

1. Fill fuel tanks outdoors away from heat, sparks, and open flames.
2. Remove portable fuel tanks from boat to refill them.
3. Always stop engine before refilling tanks.
4. Do not completely fill the fuel tanks. Leave approximately 10% of the tank volume unfilled. Fuel will expand in volume as its temperature rises and can leak under pressure if the tank is completely filled.

FEATURES & CONTROLS

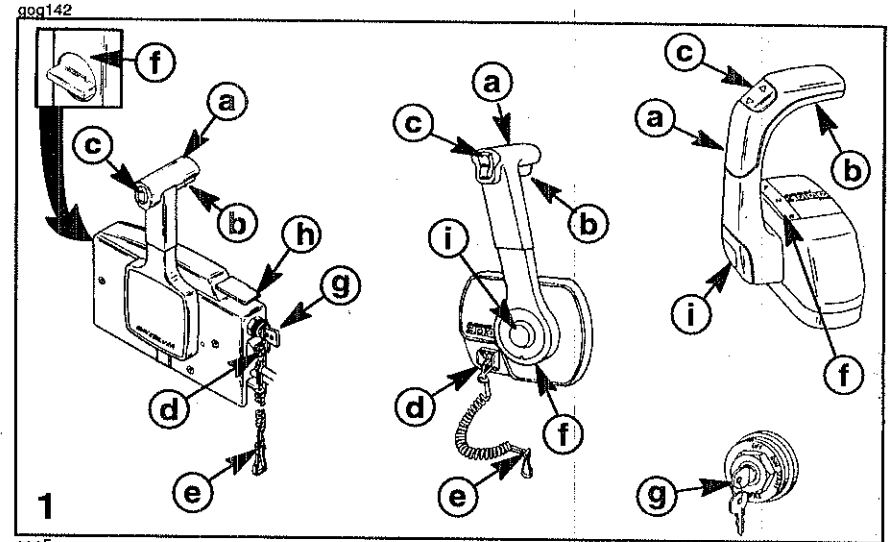

Remote Control Features

- 1 Your boat may be equipped with one of the Mercury Marine remote controls shown. If not, consult your dealer for operation of your remote control.
 - a - Control Shift/Throttle Handle
 - b - Neutral Release Lever
 - c - Trim/Tilt Switch
 - d - Lanyard Stop Switch – Read the Lanyard Stop Switch safety explanation and Warning in the General Information Section.
 - e - Lanyard – Read the lanyard stop switch safety explanation and warning in the General Information Section.
 - f - Throttle Friction Adjustment
 - g - Ignition Key Switch, Choke
 - h - Fast Idle Lever – Raising lever will increase engine idle speed in neutral.
 - i - Throttle Only Button – Pushing the button in will enable advancing the control handle and increase engine idle speed without shifting outboard into gear.

FEATURES & CONTROLS

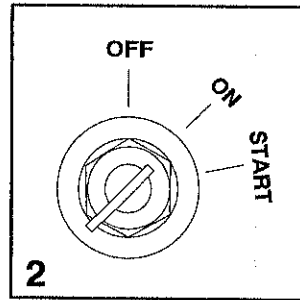
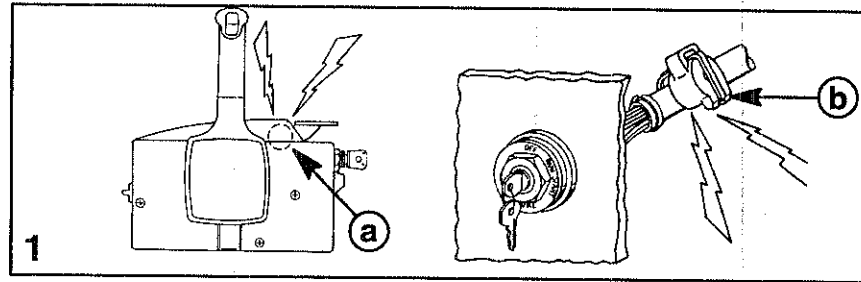

Warning Horn System

- 1 A warning horn may be located inside the remote control (a) or under the dash (b) connected to the ignition key switch.
- 2 When the ignition key is initially turned on, the warning horn will sound for a moment as a test to tell you the system is working. Failure of this test indicates a problem. Have the outboard checked by your dealer.

The warning horn will emit a continuous beep to alert the operator that the engine is above normal operating temperature (overheated).

NOTE: If you are in a stranded situation, stopping the engine and allowing it to cool down will usually allow some additional low speed (idle) running time before the engine starts to overheat again.

IMPORTANT: The overheat problem must be corrected before you can resume normal operation.

FEATURES & CONTROLS

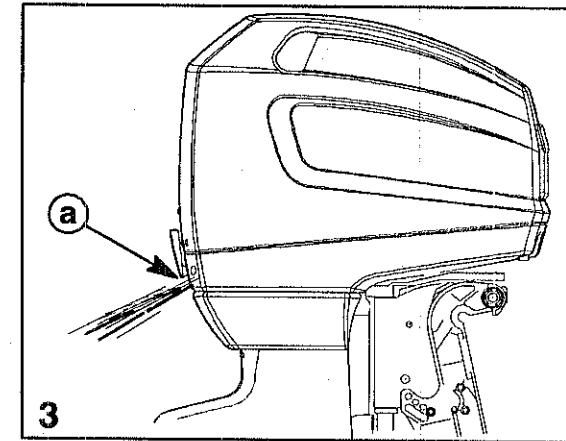

Warning Horn System (Continued)

- 3 If the engine overheats, immediately reduce throttle speed to idle. Shift outboard into neutral and check for a steady stream of water coming out of the water pump indicator hole (a).

CAUTION

Operating the engine while overheated will cause engine damage. The overheat problem must be corrected before you can resume normal operation.

- a. If no water is coming out of the water pump indicator hole (a) or flow is intermittent:
 - Stop engine and check cooling water intake holes for obstruction.
 - If no obstruction is found, this may indicate a blockage in the cooling system or a water pump problem.
 - Have the outboard checked by your dealer.
- b. If a steady stream of water is coming out of the water pump indicator hole (a) and the warning horn continues to sound:
 - There may be insufficient cooling water or an engine problem.
 - Stop engine and have it checked by your dealer.

ag

FEATURES & CONTROLS

qcg70

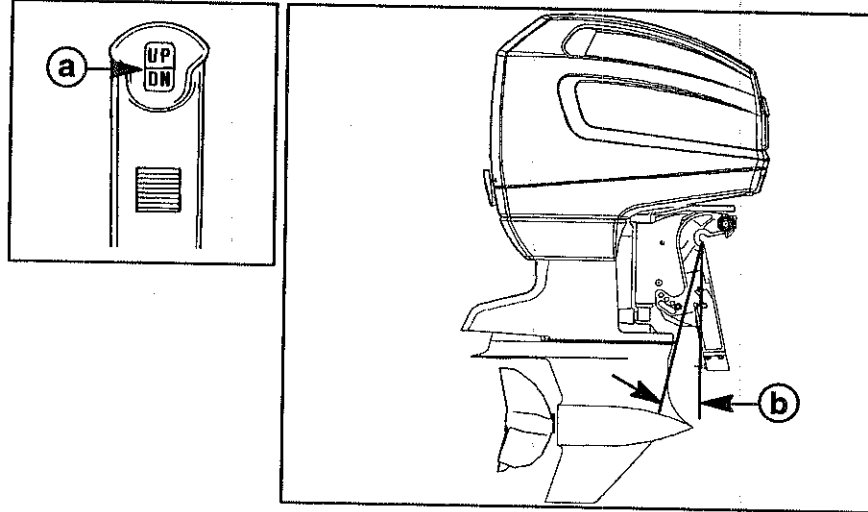

Power Trim And Tilt

Outboard position can be adjusted by pressing trim switch (a). This range is used while operating your boat on plane.

- **Pressing (DN):** Moves the outboard in closer to the boat transom, called trimming "in" or "down."
- **Pressing (UP):** Moves the outboard further away from the boat transom, called trimming "out" or "up."

The term "trim":

- Generally refers to the adjustment of the outboard within the first 20° range of travel (b).

The term "tilt":

- Generally refers to adjusting the outboard further up out of the water.

With the engine turned off, the outboard can be tilted out of the water. At low idle speed, the outboard can also be tilted up past the trim range to permit, for example, shallow water operation.

(continued on next page)

FEATURES & CONTROLS

ost1

Power Trim Operation

With most boats, operating around the middle of the "trim" range will give satisfactory results. Trimming your outboard all the way in or out may improve performance but cause some potential control hazards.

WARNING

Avoid possible serious injury or death. When the outboard is trimmed in or out beyond a neutral steering condition, a pull on the steering wheel in either direction may result. Failure to keep a continuous firm grip on the steering wheel when this condition exists can result in loss of boat control as the outboard can turn freely. The boat can now "spin out" or go into a very tight maximum turn which, if unexpected, can result in occupants being thrown within the boat or out of the boat.

Consider the following lists carefully.

Trimming In or Down Can:

- Lower the bow of the boat.
- Result in quicker planing off.
- Generally improve the ride in choppy water.
- Increase steering torque or pull to the right (with the normal right hand rotation propeller).
- In excess, lower the bow to a point at which the boat begins to plow with the bow in the water while on plane. This can result in an unexpected turn in either direction called "bow steering" or "over steering" if any turn is attempted, or if a significant wave is encountered.

(continued on next page)

FEATURES & CONTROLS

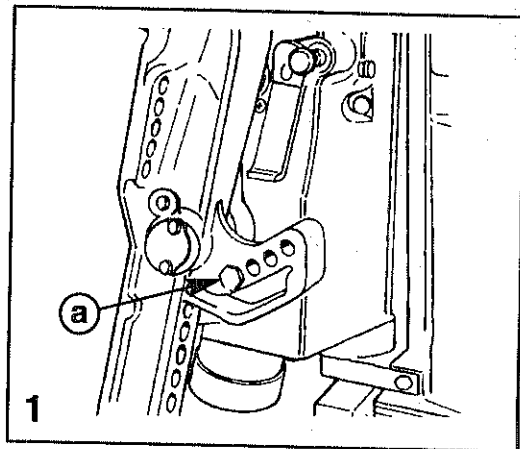

osf1

Power Trim Operation (continued)

▲ WARNING

Avoid possible serious injury or death. Adjust outboard to an intermediate trim position as soon as boat is on plane to avoid possible ejection due to boat spin-out. Do not attempt to turn boat when on plane if outboard is trimmed extremely in or down and there is a pull on the steering wheel.

- 1 The trim in limit may be set by inserting the tilt pin (a) into the desired transom bracket hole.

Trimming Out or Up can:

- Lift the bow higher out of the water.
- Generally increase top speed.
- Gain clearance over submerged objects or a shallow bottom.
- Increase steering torque or pull to the left at a normal installation height (with the normal right hand rotation propeller).
- In excess, cause boat "porpoising" (bouncing) or propeller ventilation.
- Cause engine overheating if any cooling water intake holes are above the water line.

FEATURES & CONTROLS

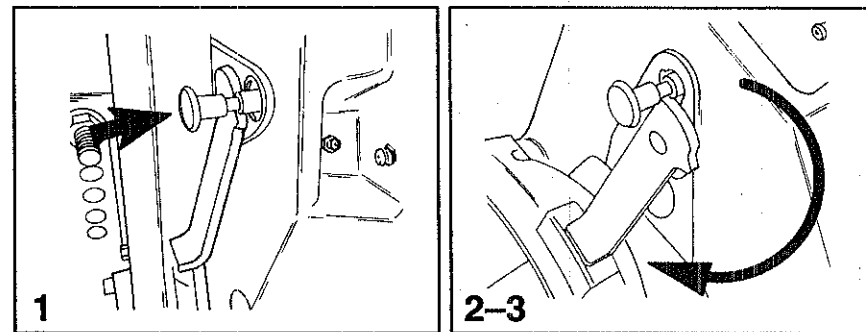

Tilting Operation

To tilt outboard, shut off the engine and press the trim/tilt switch to the up position. The outboard will tilt up until the switch is released or it reaches its maximum tilt position.

- 1 Push in on the tilt support release knob.
- 2 Move tilt support lever into locking position and lower outboard to rest on the tilt support lever.
- 3 Disengage the tilt support lever by raising the outboard off the support lever and rotating the lever up until it locks. Lower the outboard.

FEATURES & CONTROLS

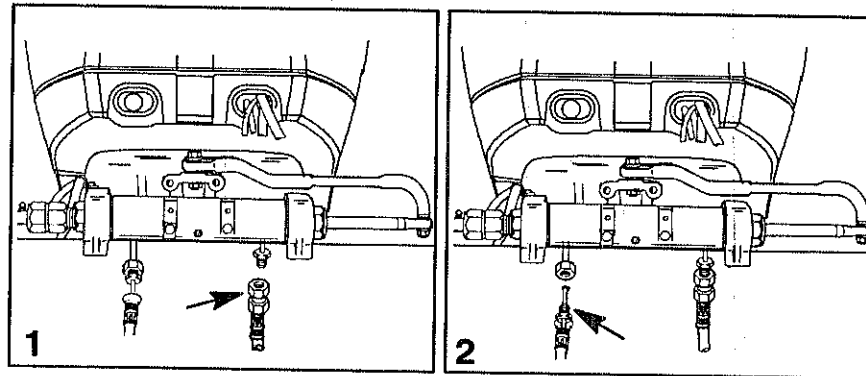

Manual Tilting

If the outboard cannot be tilted using the power trim/tilt switch, the outboard can be manually tilted by the following procedures.

⚠ CAUTION

The engine must be supported during lowering in the following steps or the engine may drop rapidly and personal injury as well as damage to the engine could occur.

NOTE: Place a suitable container below the connection and wrap the connection with a cloth to collect any fluid which may be dispelled during the following operations.

1 TILTING (DOWN / IN):

- Loosen the (starboard-right, facing engine from front) hydraulic connection at the front of the swivel bracket.
- Slowly lower the engine to the desired position, and reconnect the hydraulic connection.

2 TILTING (UP / OUT):

- Loosen the (port-left, facing engine from front) hydraulic connection at the front of the swivel bracket.
- Slowly lift the engine and engage the tilt lock lever. Reconnect the hydraulic connection.

IMPORTANT: If the hydraulic lines are disconnected and fluid is lost, the power trim pump must be refilled and the lines purged of air.

OPERATION

Engine Break-in - 2.5 EFI, SS, And Offshore

⚠ CAUTION

Severe damage to the engine can result by not complying with the Engine Break-in Procedure.

BREAK-IN PROCEDURE

During Break-in, mix oil and gasoline at a 40:1 ratio (2.5%)

Always vary throttle setting during Break-in.

First 2 hours of operation:

1. AVOID WIDE OPEN THROTTLE.
2. AVOID FULL THROTTLE ACCELERATION.
3. AVOID REMAINING AT A CONSTANT SPEED FOR MORE THAN 2 MINUTES
4. AVOID SUSTAINED IDLE OR RUNNING BELOW 1500 RPM.

1st hr.	Do not exceed 1/2 throttle or 3500 RPM
2nd hr.	Do not exceed 4500 RPM
Hours 3-10	Do not operate at wide open throttle for more than 2 minutes

Gasoline Recommendation

Use a major brand of automotive unleaded gasoline with a minimum posted octane rating (R + M + 2) of 92.

Oil Recommendation

Use Mercury Precision 2-Cycle Performance Blend Oil (92-813743A2).

OPERATION

Pre-starting Check List

- Engine lowered to run position with all water intake holes submerged.
- Fuel tank vent cap open or fuel petcock "On".
- Fuel supply OK.
- Lanyard stop switch in "Run" position and cord connected.
- Remote control in "Neutral".
- Top cowl latches secure.
- Make inspection checks listed in the Inspection and Maintenance Schedule. Refer to Maintenance Section.

one²

Operating In Freezing Temperatures

When using your outboard or having your outboard moored in freezing or near freezing temperature, keep the outboard tilted down at all times so the gear case is submerged. This prevents trapped water in gear case from freezing and causing possible damage to the water pump and other components.

If there is a chance of ice forming on the water, the outboard should be removed and drained completely of water. If ice should form at the water level inside the outboard drive shaft housing, it will block water flow to the engine causing possible damage.

OPERATION

one¹

Operating In Salt Water Or Polluted Water

We recommend flushing the internal water passages of your outboard with fresh water after each use in salt or polluted water to prevent a buildup of deposits from clogging the water passages. Refer to "Flushing The Cooling System" procedure in the Maintenance Section.

If you keep your boat moored in the water, always tilt the outboard so the gear case is completely out of water (except in freezing temperature) when not in use.

Wash down the outboard exterior and flush out the exhaust outlet of the propeller and gear case with fresh water after each use. Each month, spray Mercury Marine Corrosion Guard on external metal surfaces (do not spray on corrosion control anodes as this will reduce the effectiveness of the anodes).

Operating At High Elevations

Your engine automatically compensates for high elevation changes. A different pitch propeller may help reduce some normal performance loss resulting from reduced oxygen in the air. Consult your dealer.

OPERATION

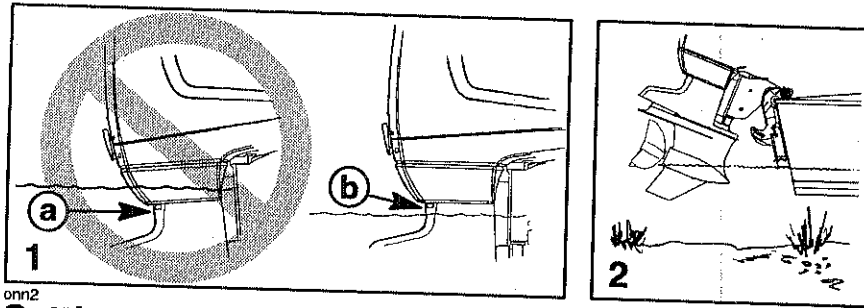

onk2

Setting Trim Angle While Running Engine at Idle Speed

- 1 Submerging the exhaust relief hole (a) on the outboard can happen on some boats if you trim "full-in" while running at idle speed, resulting in, exhaust restriction, rough idle, excessive smoke, and fouled spark plugs. If this condition exists, trim outboard up until exhaust relief hole is out of the water (b).

onk2

Operating in Shallow Water

- 2 When operating in shallow water, you can tilt the outboard beyond the maximum trim range to prevent hitting bottom.
 - a. Operate the engine at slow speed only. Do Not exceed 1200 RPM with the outboard trimmed beyond the side supports of the swivel bracket.
 - b. Tilt outboard up. Make sure all the cooling water intake holes stay submerged at all times.

OPERATION

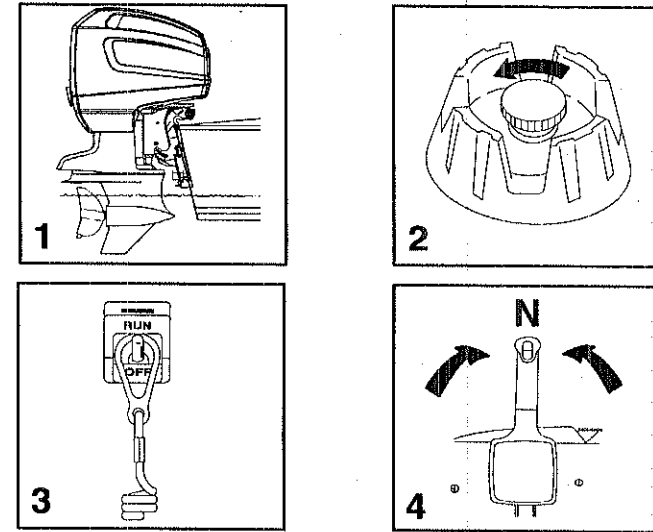

Starting The Engine

Before starting, read the Pre-Starting Check List, Special Operating Instructions, in the Operation Section.

CAUTION

Never start or run your outboard (even momentarily) without water circulating through all the cooling water intake holes in the gear case to prevent damage to the water pump (running dry) or overheating of the engine.

- 1 Lower the outboard to the run position. Make sure all the cooling water intake holes are submerged.
- 2 Open fuel tank filler cap vent screw (manual venting fuel tanks).
- 3 Set the lanyard stop switch to RUN position. Read the Lanyard Stop Switch safety explanation and Warning in the General Information Section.
- 4 Shift outboard to neutral (N) position.

OPERATION

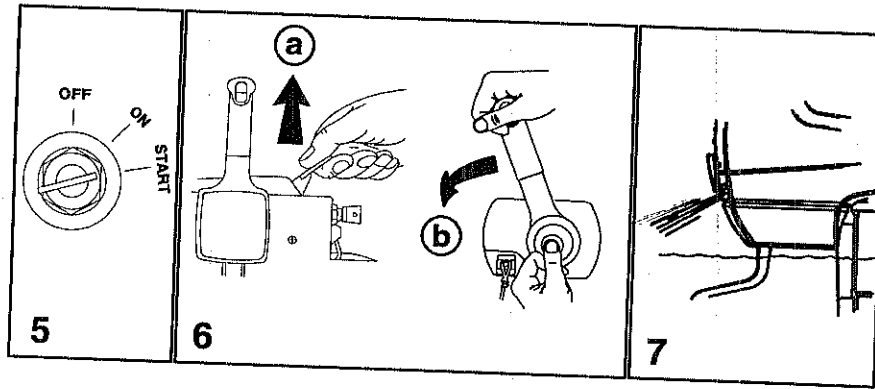

- 5 Turn the ignition key to START. Release the key when engine starts. If engine fails to start in 10 seconds, return the key to ON position, wait 30 seconds and try again.
- 6 **Starting Flooded Engine:** Raise the fast idle speed lever (a) or push in throttle only button and advance throttle lever (b) to the maximum position. Crank engine for 10 seconds. Wait 30 seconds and repeat if required. Immediately reduce engine speed after engine starts. **After starting, keep engine speed below 2500 RPM to prevent engine over-speed.**
- 7 A steady water stream must be present from the water pump indicator hole with engine running.

IMPORTANT: If no water is coming out of the water pump indicator hole, immediately stop engine, refer to "Troubleshooting".

OPERATION

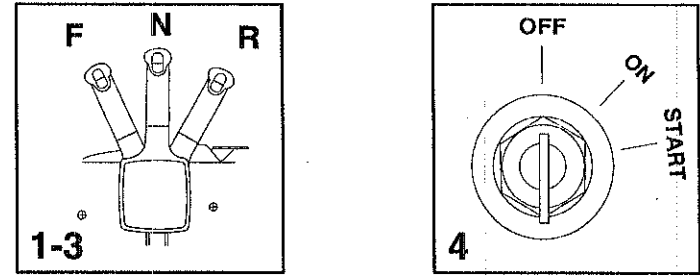

Starting The Engine (Continued)

Gear Shifting

IMPORTANT: Observe the following:

- Never shift outboard into gear unless engine is at idle.
 - Never shift outboard into Reverse without the engine running.
- 1 Your outboard has three gear shift positions to provide operation. Forward (F), Neutral (out of gear) and Reverse (R).
 - 2 When shifting, always stop at neutral position and allow the engine speed to return to idle.
 - 3 Always shift outboard into gear with a quick motion.

Stopping The Engine

- 4 Reduce engine speed and shift outboard to neutral position. Turn ignition key to OFF position.

MAINTENANCE

Outboard Care

To ensure safety and retain dependability keep your outboard in the best operating condition by performing the periodic inspections and maintenance listed in the Inspection and Maintenance Schedule. Record maintenance performed in Maintenance Log at the back of this book. Save all maintenance work orders and receipts.

ohr1

⚠ WARNING

Neglected outboard inspection and maintenance or performing maintenance or repairs you are not familiar with, could result in personal injury, death or product failure.

Submerged Outboard

A submerged outboard will require service within a few hours by an authorized dealer once the outboard is recovered. This immediate attention is necessary once the engine is exposed to the atmosphere to minimize internal corrosion damage to the engine.

Selecting Replacement Parts For Your Outboard

We recommend using original Mercury Marine replacement parts and Lubricants.

⚠ WARNING

Using a replacement part that is inferior to the original part could result in personal injury, death, or product failure.

MAINTENANCE

EPA Emissions Regulations

Outboards manufactured by Mercury Marine in the United States are certified to the United States Environmental Protection Agency as conforming to the requirements of the regulations for the control of air pollution from new outboard motors. This certification is contingent on certain adjustments being set to factory standards. For this reason, the factory procedure for servicing the product must be strictly followed and, wherever practicable, returned to the original intent of the design. **Maintenance, replacement, or repair of the emission control devices and systems may be performed by any marine engine repair establishment or individual.** Engines are labeled with an Emission Control Information decal as permanent evidence of EPA certification.

MAINTENANCE

ohd10

Inspection And Maintenance Schedule

BEFORE EACH USE

1. Check that lanyard stop switch stops the engine.
2. Visually inspect the fuel system for deterioration or leaks.
3. Check outboard for tightness on transom.
4. Check steering system for binding or loose components.
5. Visually check steering link rod fasteners for proper tightness.
6. Check propeller blades for damage.
7. Check level and condition of gear case lubricant.

AFTER EACH USE

1. Flush out the outboard cooling system if operating in salt or polluted water.
2. If operating in salt water, wash off salt deposits and flush propeller and gear case exhaust outlet with fresh water.

EVERY 50 HOURS OF USE OR ONCE A SEASON

IMPORTANT: Increased lubrication and corrosion maintenance is required if unit is used in salt water.

1. Lubricate all lubrication points.
2. Lubricate splines on the drive shaft.*
3. Lubricate entire length of driveshaft with anti-corrosion grease.*
4. Replace water pump impeller (more often if overheating occurs or reduced water pressure is noted).*
5. Lubricate splines on the propeller shaft.
6. Drain and replace gear case lubricant.
7. Inspect and clean/replace spark plugs.
8. Inspect fiberglass reeds.*

* *These items should be serviced by a authorized dealer.*

(continued on next page)

MAINTENANCE

ohd10

Inspection And Maintenance Schedule (Continued)

EVERY 50 HOURS OF USE OR ONCE A SEASON

9. Check fuel pressure.*
10. Check injector spray pattern.
11. Check control cable adjustments.*
12. Check engine timing setup.*
13. Inspect battery.
14. Check corrosion control anodes.
15. Check tightness of bolts, nuts and other fasteners including powerhead and gearcase fasteners.
16. Check power trim fluid.
17. Remove engine deposits with Mercury Marine Power Tune Engine Cleaner.
18. Replace Water separating fuel filter.
19. Replace final fuel filter element.*

* *These items should be serviced by a authorized dealer.*

BEFORE PERIODS OF STORAGE

1. Refer to Storage procedure.

MAINTENANCE

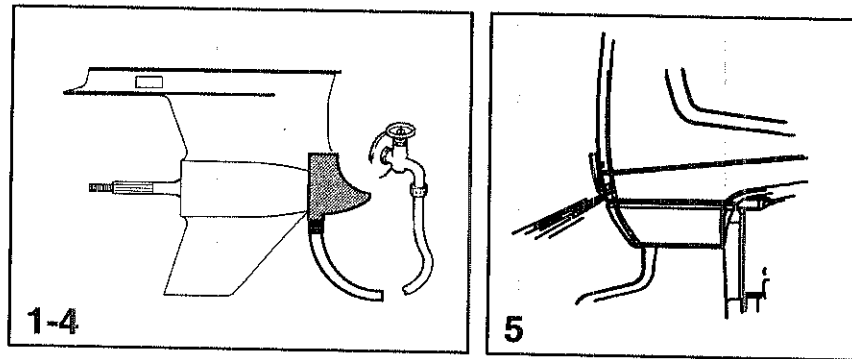

Flushing the Cooling System

⚠ WARNING

To avoid possible injury when flushing, remove the propeller. Refer to Propeller Replacement.

- 1 Remove propeller (refer to Propeller Replacement). Install the flushing attachment to fit tightly over the cooling water intake.
- 2 Attach a water hose to the flushing attachment. Turn on the water and adjust the flow so water is leaking around the flushing attachment to ensure the engine receives an adequate supply of cooling water.
- 3 Start the engine and run it at idle speed in neutral shift position.
- 4 Adjust water flow so excess water continues leaking out from around the flushing attachment to ensure the engine is receiving an adequate supply of cooling water.
- 5 Check for a steady stream of water flowing out of the water pump indicator hoses. Continue flushing the outboard for 3 to 5 minutes, carefully monitoring water supply at all times.
- 6 Stop the engine, turn off the water, and remove the flushing attachment. Reinstall the propeller.

MAINTENANCE

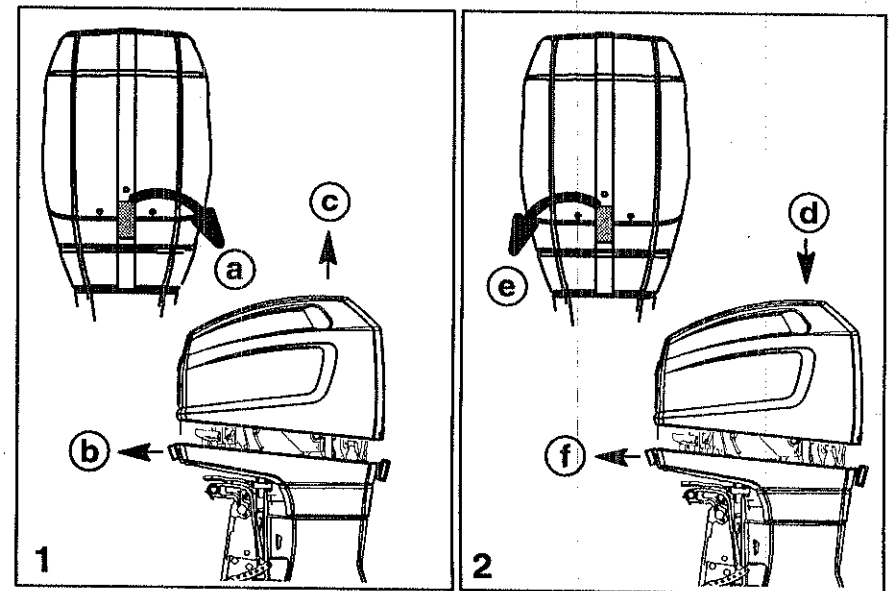

Top Cowl Removal and Installation

⚠ WARNING

Avoid Serious Injury or Death. Do Not attempt to remove or install cowl while engine is running.

1 Removal

- a - Rotate rear latching handle clockwise.
- b - Pull out on front latching handle and at the same time lift front of cowl.
- c - Lift cowl from engine.

2 Installation

- d - Lower top cowl into position over engine.
- e - Rotate the rear latch counterclockwise to secure the rear cowl latch.
- f - Pull out on front latching handle and push down on the front of the cowl to engage the front latch.

MAINTENANCE

Fuel System

⚠ WARNING

Avoid serious injury or death from gasoline fire or explosion. Carefully follow all fuel system service instructions. Always stop the engine and DO NOT smoke or allow open flames or sparks in the area while servicing any part of the fuel system.

Before servicing any part of the fuel system:

- Stop engine and disconnect the battery.
- Drain the fuel system completely.
- Fuel system service must be performed in a well ventilated area.
- Inspect any completed service work for sign of fuel leakage.

IMPORTANT: Use an approved container to collect and store fuel. Wipe up any spillage immediately. Material used to contain spillage must be disposed of in an approved receptacle.

FUEL LINE INSPECTION

Visually inspect the fuel line for cracks, swelling, leaks, hardness, or other signs of deterioration or damage. If any of these conditions are found, the fuel line must be replaced.

MAINTENANCE

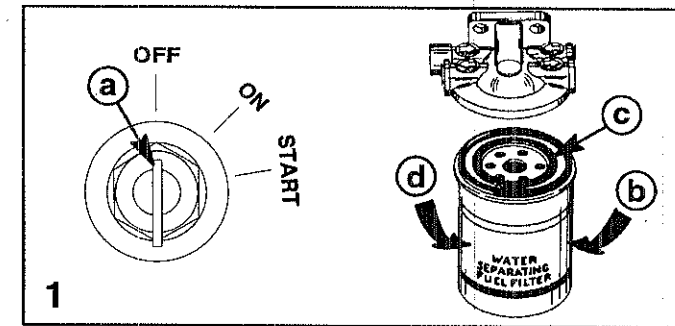

Fuel System (Continued)

WATER SEPARATING FUEL FILTER (NOT INCLUDED WITH ENGINE)

1 Remove and replace filter as follows:

- Turn ignition key switch to OFF position.
- Remove filter by turning the filter (counterclockwise). Dump fluid in a suitable container.
- Lubricate the sealing ring on the filter with oil.
- Thread on filter and tighten securely by hand.

IMPORTANT: Visually inspect for fuel leakage from the filter after starting the engine.

MAINTENANCE

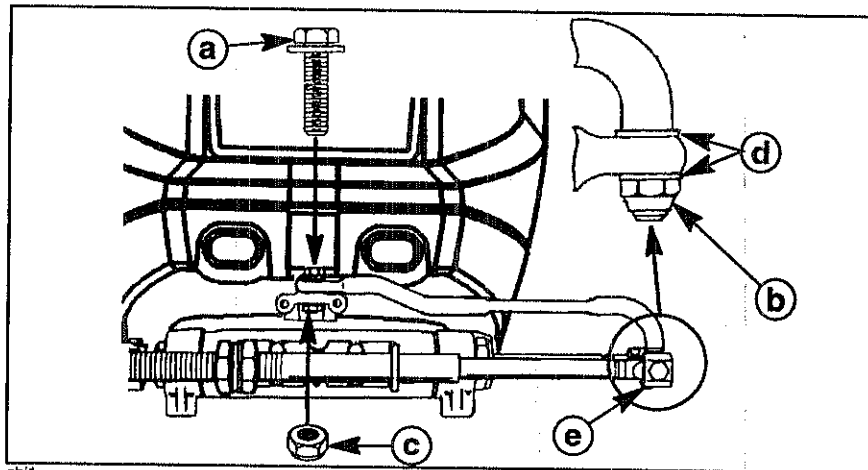

OH11

Steering Link Rod Fasteners

DUAL CABLE STEERING

Installation instructions for dual cable single engine applications are included with the dual cable kit.

IMPORTANT: The steering link rod that connects the steering cables to the engine must be fastened using special washer head bolt ("a" – Part Number 10-849838) and self locking nylon insert locknuts ("b" & "c" – Part Number 11-826709113). Never replace locknuts with common nuts (non locking) as they will work loose/vibrate off freeing link rod to disengage.

⚠ WARNING

Disengagement of a steering link rod can result in the boat taking a full, sudden, sharp turn. This potentially violent action can cause occupants to be thrown overboard exposing them to serious injury or death.

Assemble steering link rod to steering cable coupler (e) with two flat washers (d) and self locking nylon insert locknut ("b" – Part Number 11-826709113). Tighten locknut (b) until it seats, then back nut off 1/4 turn.

Assemble steering link rod to engine with special washer head bolt ("a" – Part Number 10-849838) and self locking nylon insert locknut ("c" – Part Number 11-826709113). First torque bolt (a) to 20 lb. ft. (27.1 N·m), then torque locknut (c) to 20 lb. ft. (27.1 N·m).

MAINTENANCE

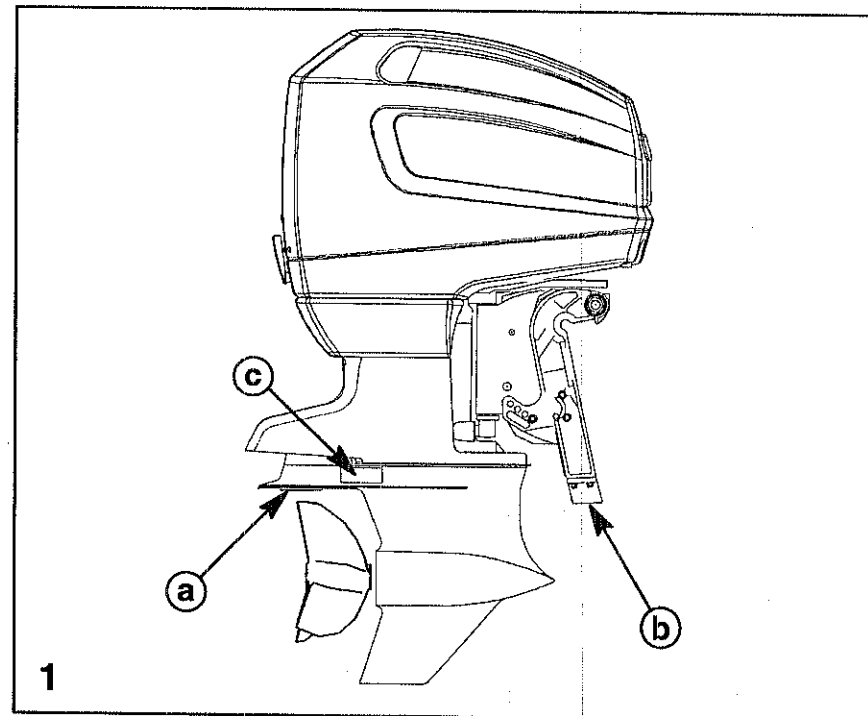

Corrosion Control Anodes

IMPORTANT: Anodes help protect the metal of the outboard from galvanic corrosion by sacrificing their metal to be slowly eroded instead of the outboard metals being eroded. All anodes require periodic inspection, especially in salt water. Replace any anodes before they are completely eroded. Never paint or apply protective coating on the anode as effectiveness of the anode will be reduced.

1 Your outboard has the following (four) corrosion control anodes.

- a - One plate installed under the anti-ventilation plate.
- b - One bar across the bottom of the transom bracket assembly.
- c - Two bars, one in each side of the driveshaft housing above the anti-ventilation plate.

MAINTENANCE

goh112

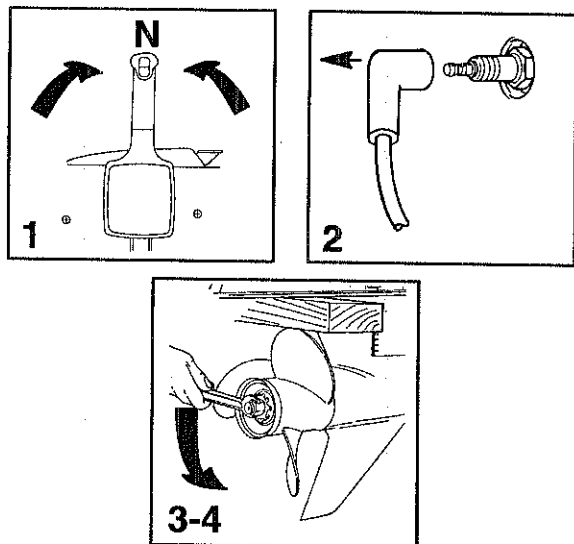

Propeller Replacement

⚠ WARNING

If the propeller is rotated while the engine is in gear, there is the possibility that the engine will crank over and start. To prevent this accidental engine starting and possible serious injury caused from being struck by a rotating propeller, always shift outboard to neutral position and remove spark plug leads before you service the propeller.

- 1 Shift outboard to neutral (N) position.
- 2 Remove spark plug leads to prevent engine from starting.
- 3 Place a block of wood between gear case and propeller to hold propeller and remove propeller nut.
- 4 If propeller is seized to the shaft and cannot be removed, consult an authorized dealer.

MAINTENANCE

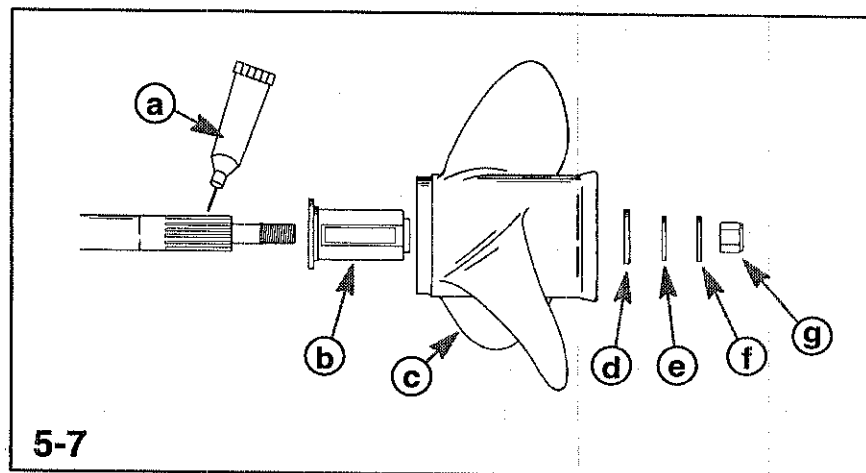

Propeller Replacement (Continued)

- 5 Coat the propeller shaft with Mercury Precision Anti-Corrosion Grease.

IMPORTANT: To prevent the propeller hub from corroding and seizing to the propeller shaft, especially in salt water, always apply a coat of the recommended lubricant to the entire propeller shaft at the recommended maintenance intervals and also each time the propeller is removed.

- 6 Heavy Duty Prop Shaft Hub Kit P/N 840389A2
(Included with engine) Coat propshaft with Mercury Precision Anti-Corrosion Grease (a) (92-802867A1). Install prop hub assembly (b), propeller (c), washer (d), Belleville washer (e), washer (f), and propeller nut (g) onto the shaft.
- 7 Place a block of wood between gear case and propeller and torque propeller nut to 55 lb. ft. (75 N-m).

MAINTENANCE

goh63

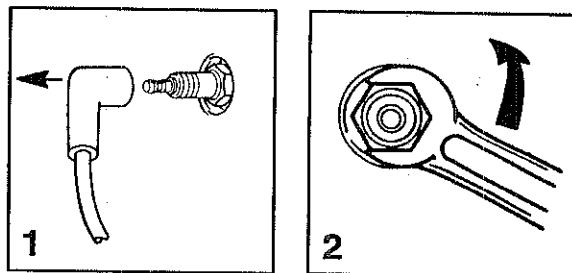

ohm4

Spark Plug Inspection

Inspect spark plugs at the recommended intervals.

- 1 Remove the spark plug leads by twisting the rubber boots slightly and pull off. Inspect spark plug boots and replace if cracked.
- 2 Remove the spark plugs to inspect and clean. Replace spark plug if electrode is worn or the insulator is rough, cracked, broken, blistered, or fouled.
- 3 Before reinstalling spark plugs, clean away dirt on the spark plug seats. Install plugs finger tight, and tighten 1/4 turn or torque to 20 lb. ft. (27 N·m).

Battery Inspection

The battery should be periodically inspected.

IMPORTANT: Read the safety and maintenance instructions which accompany your battery.

1. Turn off the engine before servicing the battery.
2. Add water as necessary to keep the battery full.
3. Make sure the battery is secure.
4. Battery cable terminals should be clean, tight, and positive to positive and negative to negative.
5. Make sure the battery is equipped with nonconductive terminal shields to prevent accidental shorting of battery terminals.

MAINTENANCE

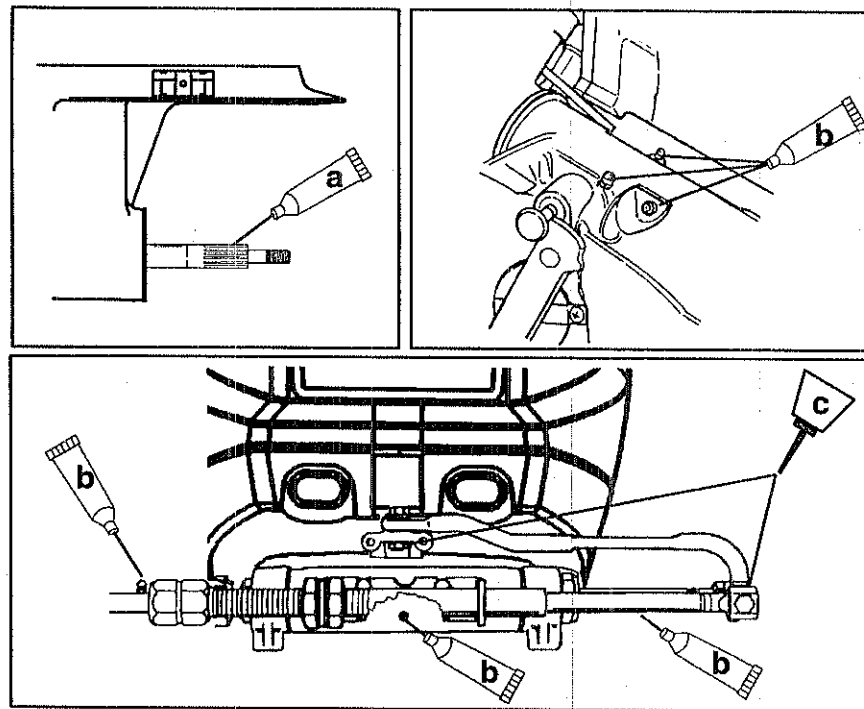

Lubrication Points

- a - Mercury Precision Anti-Corrosion Grease (92-802867A1)
- b - Mercury Precision 2-4-C w/Teflon (92-802859A1) or Mercury Precision Special Lubricant 101 (92-802865A1)
- c - Light Weight Oil

NOTE: Propeller Shaft – Refer to *Propeller Replacement* for removal and installation.

⚠ WARNING

The end of the steering cable must be fully retracted into the outboard tilt tube before adding lubricant thru grease fitting. Adding lubricant to steering cable when fully extended could cause steering cable to become hydraulically locked. An hydraulically locked steering cable could cause loss of steering control, possibly resulting in serious injury or death.

(continued on next page)

MAINTENANCE

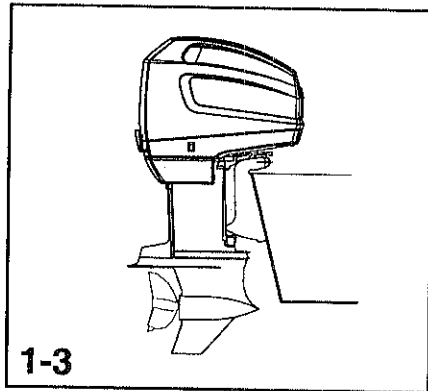

1-3

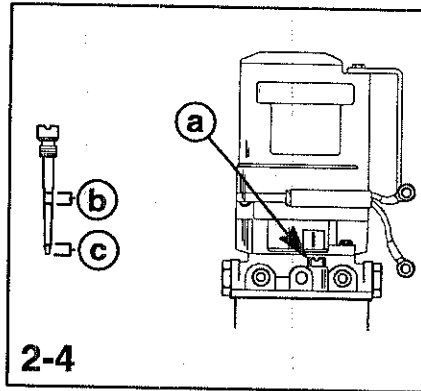

2-4

Checking Power Trim Fluid

- 1 Place outboard in the full down (in) position.
- 2 Remove trim pump fill/vent screw (a)
 - Wipe fill/vent screw with a clean, lint-free cloth and reinstall - DO NOT THREAD INTO PUMP.
 - Remove fill/vent screw and note oil level. Oil level must be between the "ADD" (c) and "FULL" (b) marks on dipstick.
 - If necessary, add Mercury Precision Power Trim & Steering Fluid. (92-802880A1) or SAE 10W-30 or 10W-40 motor oil thru the fill/vent screw hole to bring level up to the "FULL" mark on the dipstick. DO NOT OVERFILL.
- 3 To purge system of air, raise the outboard 2 or 3 times. Recheck oil level and add oil if necessary.
- 4 Reinstall fill/vent screw by turning it all-the-way in, then back it out one and a half (1-1/2) turns.

CAUTION

Fill/Vent screw **MUST BE** backed out one and a half (1-1/2) turns (after bottoming out) to vent pump reservoir. **FAILURE TO BACK SCREW OUT COULD RESULT IN DAMAGE TO PUMP.**

MAINTENANCE

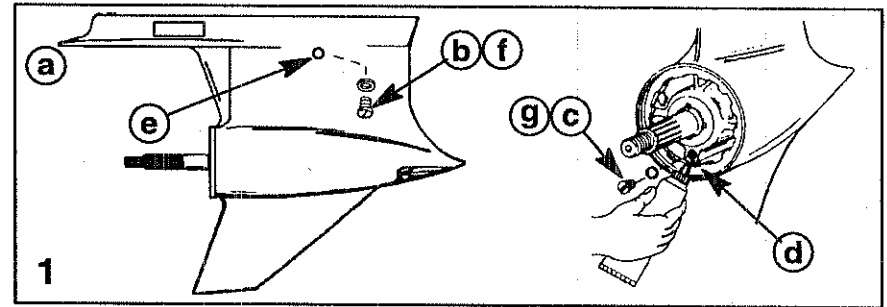

Gear Case Lubricant

Water in Gear Lubricant May:

- Settle to bottom and drain out with the lubricant.
- Be mixed with lubricant giving a milky color to lubricant.

Water in Gear Lubricant Will:

- Result in premature bearing failure.
- In freezing temperatures, turn to ice and damage gearcase.

1 Checking Gear Case Lubricant / Refilling Gear Case

- a - Place outboard in a vertical operating position.
- b - Remove the (upper) Vent plug and sealing washer.
- c - Remove the (lower) Fill/Drain plug.

NOTE: Examine the magnetic fill/drain plug for metal particles. A small amount of metal filings or fine metal particles indicates normal gear wear. An excessive amount of metal filings or larger particles (chips) should be checked by an authorized dealer.

- d - Quickly place lubricant tube into the fill hole.
- e - Slowly add lubricant until it flows from the (upper) vent hole.

IMPORTANT: Replace sealing washers if damaged.

- f - Stop adding lubricant. Install the (upper) vent plug and sealing washer before removing the lubricant tube.
- g - Remove lubricant tube and reinstall cleaned (lower) fill/drain plug and sealing washer.

MAINTENANCE

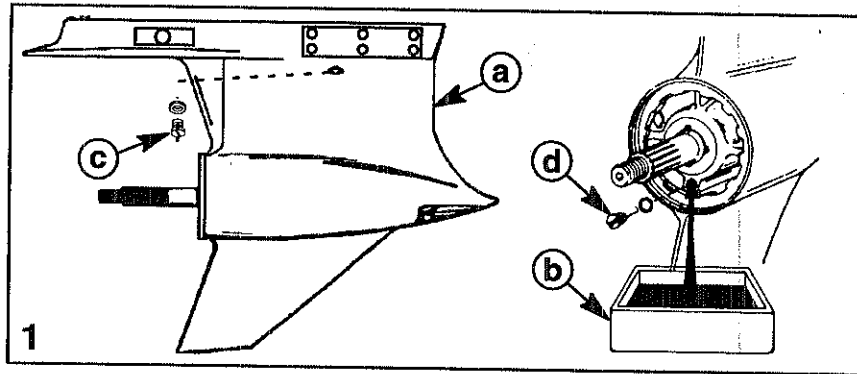

Gear Case Lubricant (Continued)

1 Draining Gear Case

- a - Place outboard in a vertical operating position.
- b - Place drain pan below outboard.
- c - Remove (upper) vent plug and sealing ring.
- d - Remove (lower) fill/drain plug and sealing ring and drain lubricant.

ohv8

GEAR CASE LUBRICANT CAPACITY

Gear case lubricant capacity is approximately 22.5 fl. oz. (666 ml).

oi

STORAGE

oia2

Storage Preparation

The major consideration in preparing your outboard for storage is to protect it from rust, corrosion, and freezing water damage.

The following storage procedures should be followed to prepare your outboard for out of season storage or prolonged storage (two months or longer).

Positioning Outboard for Storage

Store outboard in an upright (vertical) position to allow water to drain out of outboard.

CAUTION

If outboard is stored tilted up in freezing temperature, water may enter the propeller exhaust outlet in the gear case and could freeze causing damage to the outboard.

oib11

FUEL SYSTEM

IMPORTANT: Gasoline containing alcohol (ethanol or methanol) can cause a formation of acid during storage and can damage the fuel system. If the gasoline being used contains alcohol, it is advisable to drain as much of the remaining gasoline as possible from the fuel tank, remote fuel line, and engine fuel system.

To prevent varnish or gum buildup during extended storage, we recommend adding Mercury Precision Fuel System Treatment and Stabilizer (92-802875A1) to the fuel tank and operation of the engine to introduce the additives to the system.

STORAGE

Fuel System (Continued)

1. Portable Fuel Tank – Pour the required amount of Mercury Precision Fuel System Treatment and Stabilizer (92-802875A1) (follow instructions on container) into fuel tank. Tip fuel tank back and forth to mix stabilizer with the fuel.
2. Permanently Installed Fuel Tank – Pour the required amount of Mercury Precision Fuel System Treatment and Stabilizer (92-802875A1) (follow instructions on container) into a separate container and mix with approximately one quart (one liter) of gasoline. Pour this mixture into fuel tank.

▲ CAUTION

Prevent damage to the water pump or overheating of the engine, never start or run your outboard (even momentarily) without an adequate water supply to the engine.

3. Place the outboard in water or connect flushing attachment for circulating cooling water. Run the engine for ten minutes to allow treated fuel to fill the fuel system.

^{hid1}Protecting Internal Engine Components

NOTE: Before performing the following steps, make sure the fuel system has been prepared for storage. Refer to Fuel System.

1. Remove the spark plugs and inject a five second spray of Mercury Precision Storage Seal Rust Inhibitor (92-802878-56) around the inside of each cylinder.
2. Rotate the flywheel manually several times to distribute the storage seal in the cylinders. Reinstall spark plugs.
3. Remove the water separating fuel filter and empty contents in a suitable container. Refer to Maintenance Section for removal and installation of filter. Replace fuel filter annually, or every 100 Hours of operation, or if large amount of fuel contamination is present.

oi

STORAGE

oic7

Protecting External Outboard Components

1. Lubricate all outboard components listed in the Inspection and Maintenance Schedule.
2. Touch up any paint nicks. See dealer for touch-up paint.
3. Spray Mercury Precision Corrosion Guard (92-802878-55) on external metal surfaces, (Do not apply on corrosion control anodes).

oib1

Gear Case

1. Drain and refill the gear case lubricant (refer to maintenance procedure).

BATTERY STORAGE

1. Follow the battery manufacturers instructions for storage and recharging.
2. Remove the battery from the boat and check water level. Recharge if necessary.
3. Store the battery in a cool, dry place.
4. Periodically check the water level and recharge the battery during storage.

TROUBLESHOOTING

1 – STARTER MOTOR WILL NOT CRANK THE ENGINE

POSSIBLE CAUSES

- Blown 20 Amp fuse in the starting circuit. Refer to Maintenance Section.
- Outboard is not shifted to neutral position.
- Weak battery or battery connections are loose or corroded.
- Ignition key switch failure.
- Wiring or electrical connection faulty.
- Starter motor or starter solenoid failure.

2 – ENGINE WILL NOT START

POSSIBLE CAUSES

- Lanyard stop switch not in RUN position.
- Incorrect starting procedure. Refer to Operating Section.
- Old or contaminated gasoline.
- Engine flooded. Refer to Operating Section.
- Fuel is not reaching the engine.
 - a. Fuel tank is empty.
 - b. Fuel tank vent not open or restricted.
 - c. Fuel line is disconnected or kinked.
 - d. Fuel filter is obstructed. Refer to Maintenance Section.
 - e. Fuel pump failure.
 - f. Fuel tank filter obstructed.
- Ignition system component failure.
- Spark plugs fouled or defective. Refer to Maintenance Section.

TROUBLESHOOTING

3 – ENGINE RUNS ERRATICALLY

POSSIBLE CAUSES

- Spark plugs fouled or defective. Refer to Maintenance Section.
- Incorrect setup and adjustments.
- Fuel is being restricted to the engine.
 - a. Fuel injectors obstructed.
 - b. Fuel tank filter obstructed.
 - c. Water separating filter or In-Line filter clogged.
 - d. Stuck anti-siphon valve on built in fuel tank.
 - e. Fuel line is kinked or pinched.
 - f. Reed valve open or broken.
- Fuel pump failure.
- Ignition system component failure.

4 – PERFORMANCE LOSS

POSSIBLE CAUSES

- Throttle not opening fully.
- Damaged or improper size propeller.
- Incorrect engine timing, adjustments, or setup.
- Boat overloaded or load improperly distributed.
- Excessive water in bilge.
- Boat bottom is dirty or damaged.

TROUBLESHOOTING

5 – BATTERY WILL NOT HOLD CHARGE

POSSIBLE CAUSES

- Battery connections are loose or corroded.
- Low electrolyte level in battery.
- Inefficient battery.
- Excessive use of electrical accessories.
- Defective alternator, or voltage regulator.

6 – ENGINE OVERHEATING (CONTINUOUS HORN SOUND)

POSSIBLE CAUSES

- Cooling system clogged
- Engine overloaded (cannot attain recommended RPM)
- Incorrect ignition timing
- Incorrect transom height (water pickups not getting adequate water supply)
- Not enough oil in fuel mixture
- Lean fuel mixture

NOTES

ENGINE WIRING DIAGRAM

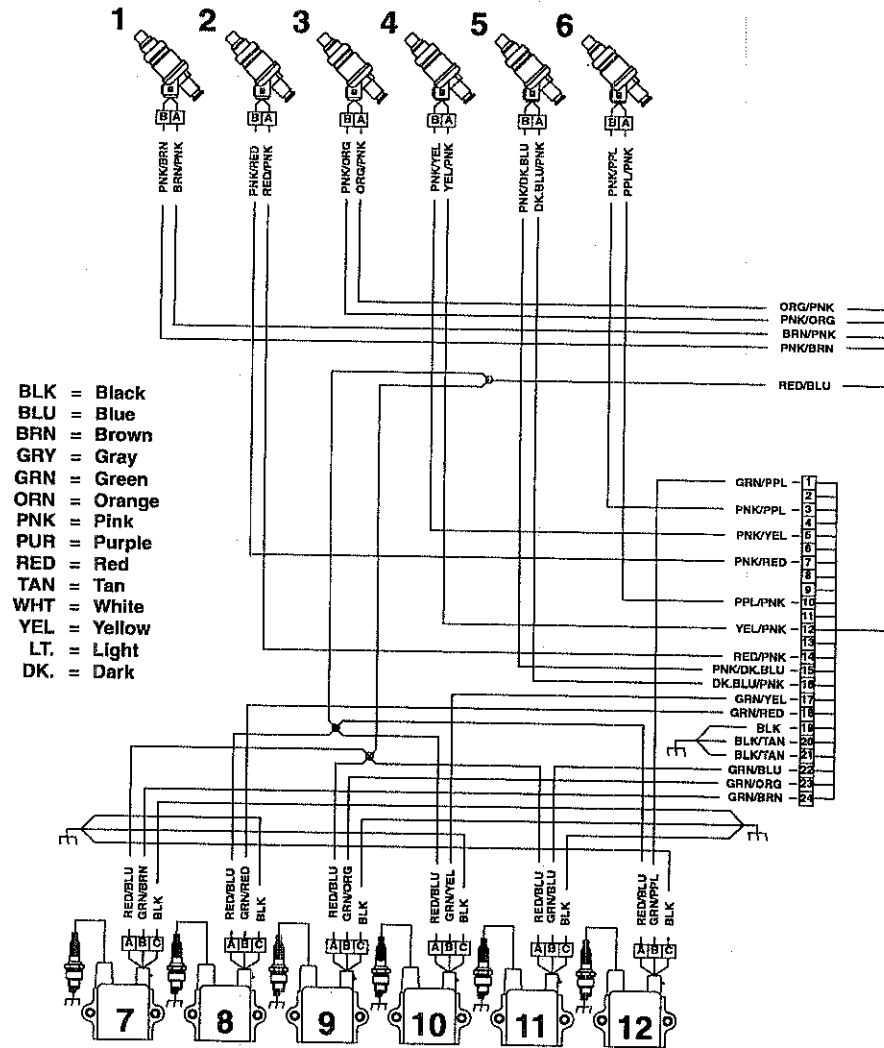

- | | | |
|---------------------|----------------------------------|------------------------------|
| 1-Fuel Injector #1 | 11-Ignition Coil #5 | 21-Fuel Pump |
| 2-Fuel Injector #2 | 12-Ignition Coil #6 | 22-12 Volt Battery |
| 3-Fuel Injector #3 | 13-MAP Sensor | 23-Starter Solenoid |
| 4-Fuel Injector #4 | 14-Throttle Position Sensor | 24-Remote Control |
| 5-Fuel Injector #5 | 15-Crank Position Sensor | 25-Temperature Gauge |
| 6-Fuel Injector #6 | 16-Air Temperature Sensor | 26-Main Power Relay |
| 7-Ignition Coil #1 | 17-Shift Switch | 27-Main Power Relay |
| 8-Ignition Coil #2 | 18-Cyl. Head Temp Switch | 28-Electronic Control Module |
| 9-Ignition Coil #3 | 19-Digital Diag. Terminal Sensor | 29-60 Ampere Alternator |
| 10-Ignition Coil #4 | 20-Starter | 30-Water Pressure Sensor |

ENGINE WIRING DIAGRAM

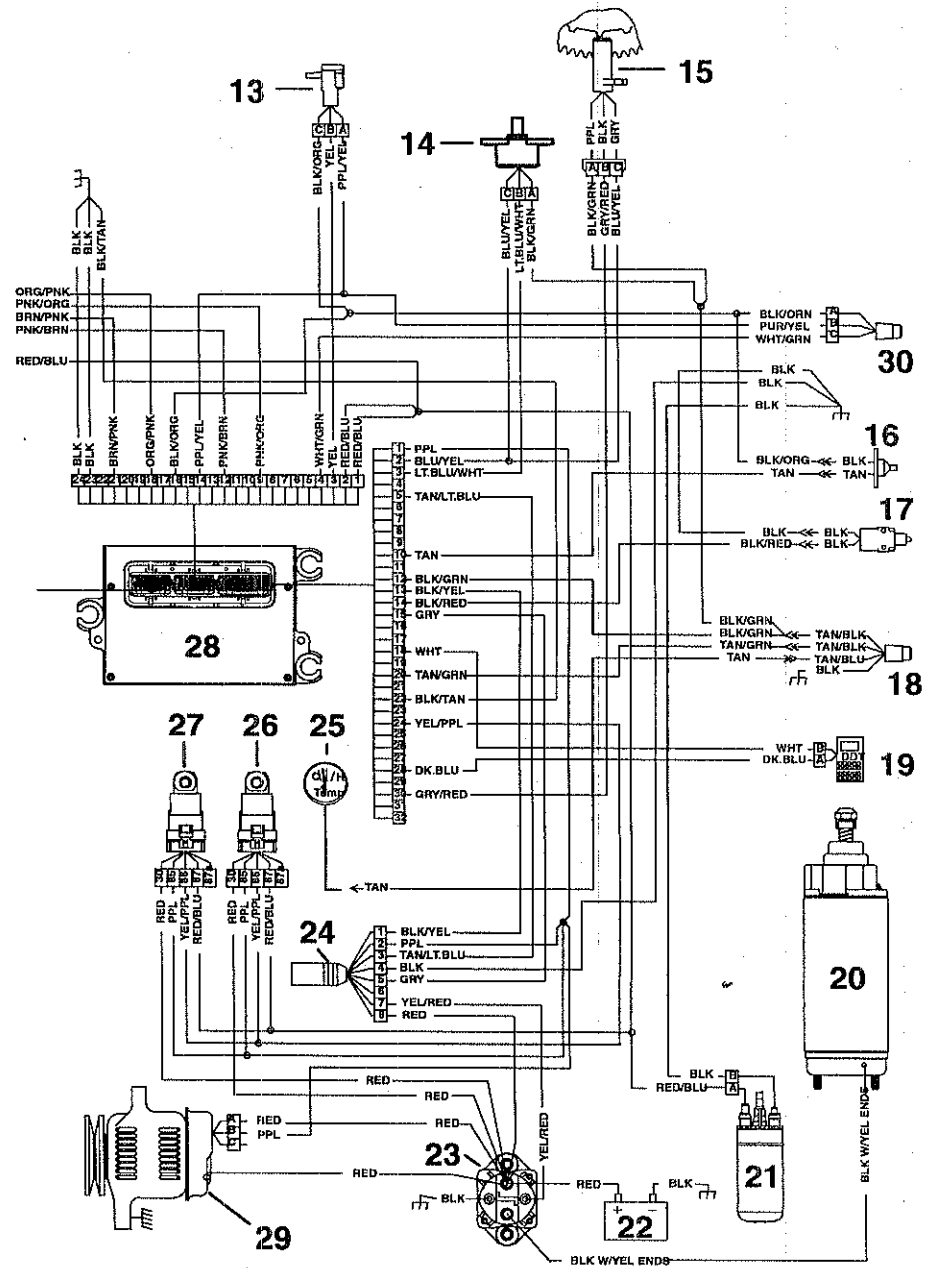

OWNER SERVICE ASSISTANCE

^{or6}

Local Repair Service

Always return your outboard to your local authorized dealer should the need for service arise. Only he has the factory-trained mechanics, knowledge, special tools and equipment and the genuine parts and accessories to properly service your engine should the need occur. He knows your engine best.

Service Away From Home

If you are away from your local dealer and the need arises for service, contact the nearest authorized dealer. Refer to the Yellow Pages of the telephone directory. If, for any reason, you cannot obtain service, contact the nearest Mercury Marine Service Office. Outside the United States and Canada, contact the nearest Marine Power International Service Center.

^{or7}

Parts And Accessories Inquiries

All inquiries concerning genuine replacement parts and accessories should be directed to your local authorized dealer. The dealer has the necessary information to order parts and accessories for you. When inquiring on parts and accessories, the dealer requires the **model** and **serial number** to order the correct parts.

OWNER SERVICE ASSISTANCE

^{or4}

Service Assistance

Your satisfaction with your outboard product is very important to your dealer and to us. If you ever have a problem, question or concern about your outboard product, contact your dealer or any Authorized Mercury Marine Dealership. If additional assistance is required, take these steps.

- 1. Talk with the dealership's sales manager or service manager. If this has already been done, then contact the owner of the dealership.*
- 2. Should you have a question, concern or problem that cannot be resolved by your dealership, please contact Mercury Marine Service Office for assistance. Mercury Marine will work with you and your dealership to resolve all problems.*

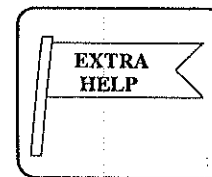
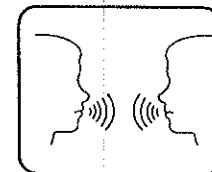

The following information will be needed by the service office:

- Your name and address
- Daytime telephone number
- Model and serial number of your outboard
- The name and address of your dealership
- Nature of problem



Mercury Marine Service Offices are listed on the next pages.

OWNER SERVICE ASSISTANCE

or5

Mercury Marine Service Offices



For assistance, call, fax, or write. Please include your daytime telephone number with mail and fax correspondence.

Telephone 	Fax 	Mail 
United States		
(920) 929-5040	(920) 929-5893	Mercury Marine W6250 W. Pioneer Road P.O. Box 1939 Fond du Lac, WI 54936-1939
United States (Mercury Racing)		
(920) 924-2088	(920) 924-2096	Mercury Racing N7480 County Rd. "UU" Fond du Lac, WI 54935-9585
Canada		
(905) 567-6372	(905) 567-8515	Mercury Marine Ltd. 2395 Meadowpine Blvd. Mississauga, Ontario Canada L5N 7W6
Australia, Pacific		
(61) (3) 9791-5822	(61) (3) 9793-5880	Mercury Marine Australia 132-140 Frankston Road Dandenong, Victoria 3164 Australia
Europe, Middle East, Africa		
(32) (87) 32-3211	(32) (87) 31-1965	Marine Power - Europe, Inc. Parc Industriel de Petit-Rechain B-4800 Verviers Belgium
Mexico, Central America, South America, Caribbean		
(305) 385-9585	(305) 385-5507	Mercury Marine - Latin America & Caribbean 9010 S.W. 137th Ave. Suite 226 Miami, FL 33186 U.S.A.

OWNER SERVICE ASSISTANCE

or5

Mercury Marine Service Offices (cont.)

Telephone 	Fax 	Mail 
Japan		
81-53-423-2500	81-53-423-2510	Mercury Marine - Japan 283-1 Anshin-cho Hamamatsu, Shizuoka, 435-0005 Japan
Asia, Singapore		
(65) 546-6160	(65) 546-7789	Mercury Marine Singapore 72 Loyang Way Singapore 508762

Ordering Literature



Before ordering literature, please have the following information about your power package available:

Model _____ Horsepower _____
Serial Number _____ Year _____

United States and Canada

For information on additional literature that is available for your particular Mercury/MerCruiser power package and how to order that literature contact your nearest dealer or contact:

Mercury Marine

Telephone 	Fax 	Mail 
(920) 929-5110	(920) 929-4894	Mercury Marine Attn: Publications Department P.O. Box 1939 Fond du Lac, WI 54936-1939

Outside The United States and Canada

Contact your nearest dealer or Marine Power Service Center for information on additional literature that is available for your particular Mercury/MerCruiser power package and how to order that literature.